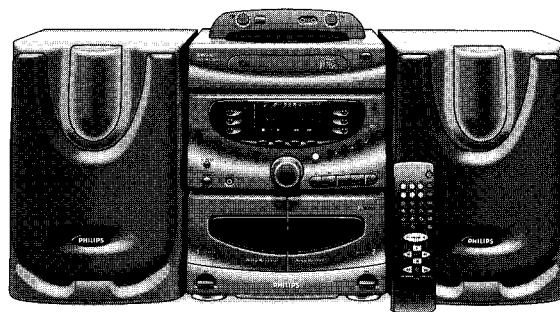


Service
Service
Service

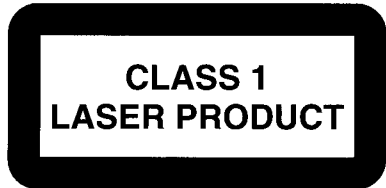


Service Manual

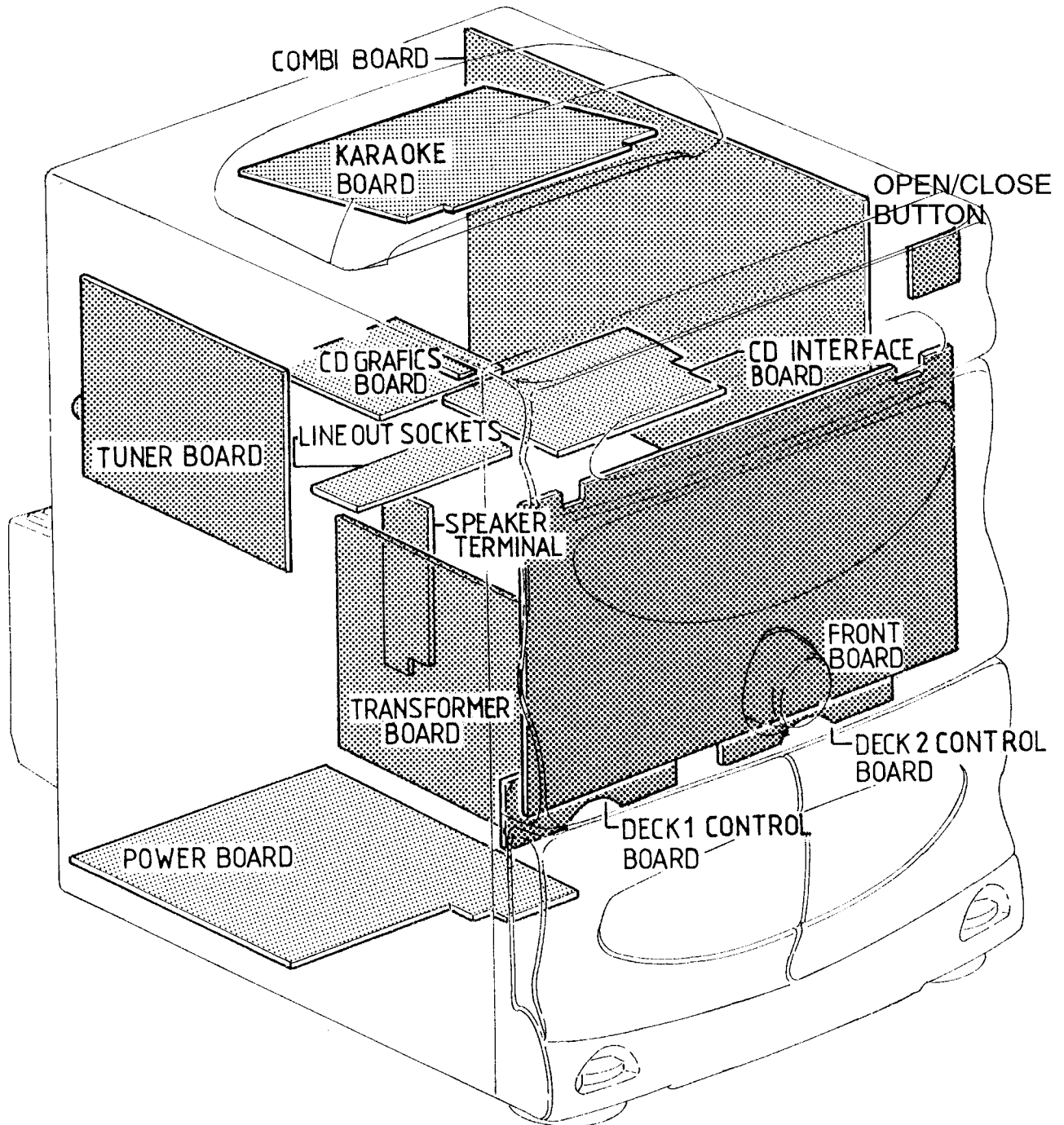


TABLE OF CONTENTS

Location of printed circuit boards.....	1-2	Tuner board	
Technical specification	2-1	Tuner ECO4VA	7A
Measurement setup	2-2	Tuner ECO5.....	7B
RC5-code	2-3	Tuner 94.....	7C
Instruction for use (excerpt).....	2-4	Karaoke board	8
Warnings & Safety	2-12	Combi board	9
 		CD Short Loader module	10
Service hints	3-1	Power board	11
Dismantling instructions.....	3-2	Exploded view tape deck	12
Service test program	3-3	Exploded view of set.....	12
 		Mechanical partslist of set	12
Block diagram	4-1		
Wiring diagram	5-1		
Control board	6		



LOCATION OF PRINTED CIRCUIT BOARDS



CD GRAPHICS BOARD not on all versions
 KARAOKE BOARD not on all versions

TECHNICAL SPECIFICATION**General:**

Mains voltage	: 230V / 50Hz for /22 and /34 : 110-127V / 220-240V switchable for /21 and /41
Power consumption	: ≤150W at maximum output power : ≤3W in power off mode

Amplifier:

Output power	: 2 x 40W at 6Ω D=10%
Music power	: 2 x 70W at 6Ω
Headphone	: 3,5mm stereo jack 2,5V EMF
Power stage protection	: Shortcircuit, AC, DC, Temperature
Frequency response	: 63 Hz - 20kHz (-3dB) Limit
Input sensitivity	
AUX/LINE	: 500mV
Microphone	: 2,5mV

Equalizer:

60Hz	: ± 6dB
1kHz	: ± 6dB
12kHz	: ±6 dB

Tuner:**FM**

Tuning range	: 87,5 - 108MHz
Grid	: 50kHz
Aerial input	: 75Ω Coax
	: 300Ω Click fit for /37
IF	: 10,7MHz ± 25kHz
Sensitivity Mono 26dB S/N	: ≤ 1,7μV
Sensitivity Stereo 46dB S/N	: ≤ 45μV
Sensitivity Search tuning	: ≤ 7μV
Distortion at RF=1mV, Δf=75kHz	: ≤ 7% (2% typ.)
Channel separation	: ≥ 26dB (30dB typ.)
Image rejection ratio	: ≥ 30dB (70dB typ.)
3 dB limiting point	: ≤ 2μV (1,5μV typ.)

MW

Tuning range	: 522 - 1611kHz
	: 530 - 1710kHz for /37
Grid	: 9kHz
	: 10kHz for /37
Aerial input	: Ferrite antenna
IF	: 450kHz ± 1kHz
Sensitivity	: ≤ 2mV/m
Distortion at RF=100mV, m=80%	: ≤ 5% (3% typ.)
Image rejection ratio	: ≥ 27dB (30dB typ.)

LW (not for 2 band versions)

Tuning range	: 153 - 279kHz
Grid	: 3kHz
Aerial input	: Ferrite antenna
IF	: 450kHz ± 1kHz
Sensitivity	: ≤ 5 mV/m
Distortion at RF=100mV, m=80%	: ≤ 5% (3% typ.)
Image rejection ratio	: ≥ 40dB (43dB typ.)

CD unit:

Have to be measured direct on internal connector 1300

Frequency response	: 20 - 20.000Hz ±2dB
Output level	: 2V ±3dB
Signal/noise ratio	: 90dB
Distortion	: < 1% at 1kHz
Channel difference	: < 2dB at 1kHz
Channel crosstalk	: 50dB max.
De emphasis	: 0 or 15/50 μs

Laser

Output power	: ≤ 500μW
Wave length	: 780nm ± 20nm

Recorder part:

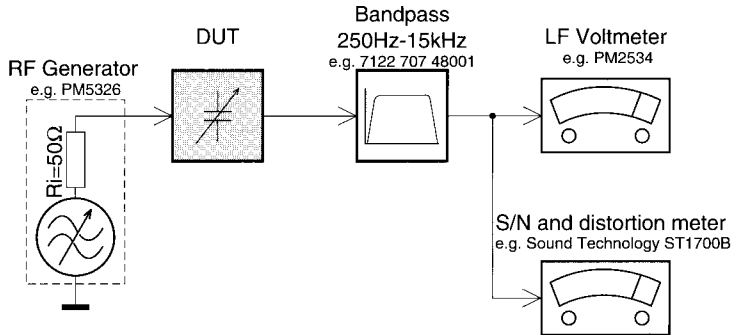
Tape speed	: 4,76cm/s ±2%
Wow & Flutter	: ≤ 0,4%
Winding speed	: ≤ 130s for C60 cassette
Erase / Bias system	: AC 80kHz ± 5kHz
RIF-shift	: service solution on request
Distortion at 200 nWb/m	: ≤ 3%
Channel difference at PB	: ≤ 3dB
Channel difference overall	: ≤ 3dB
Channel separation	: ≥ 18dB at 1kHz
Track separation	: ≥ 55dB at 1kHz
ALC attack time	: ≤ 15ms
ALC recovery time	: ≥ 50s

Frequency response	: 60Hz - 14kHz within 8dB
Signal to Hiss ratio ¹⁾	: typ 52dB with Fe
	: typ 54dB with CrO ₂
Signal to Noise ratio ²⁾	: typ 47dB with Fe
	: typ 47dB with CrO ₂
Erase attenuation ³⁾	: ≥ 62dB

¹⁾ at 250 nW/m A-weighted²⁾ at 250 nW/m FF-weighted³⁾ use a 1kHz passfilter to minimize the wide band noise component.

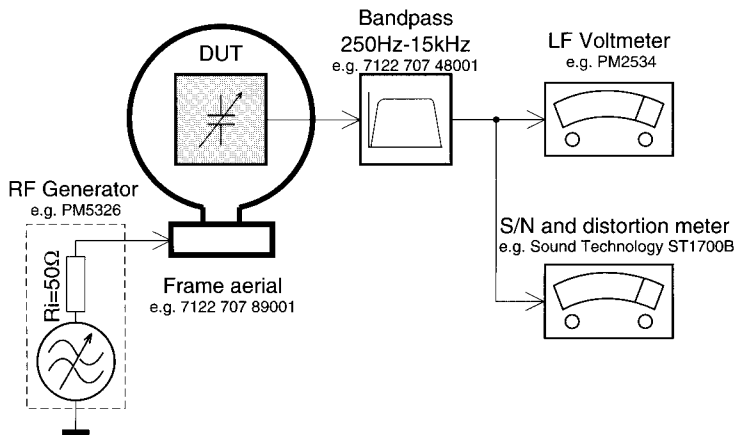
MEASUREMENT SETUP

Tuner FM



Use a bandpass filter to eliminate hum (50Hz, 100Hz) and disturbance from the pilotone (19kHz, 38kHz).

Tuner AM (MW,LW)



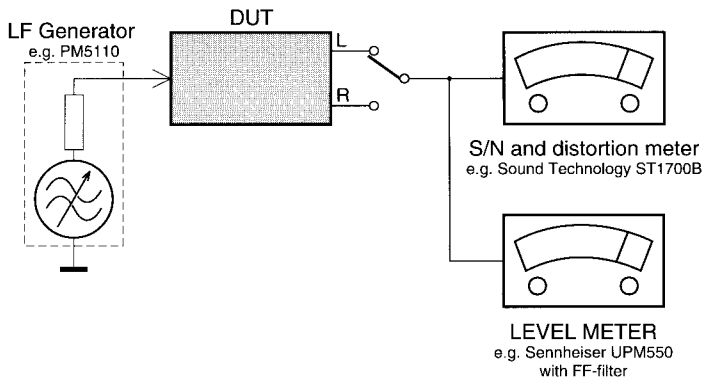
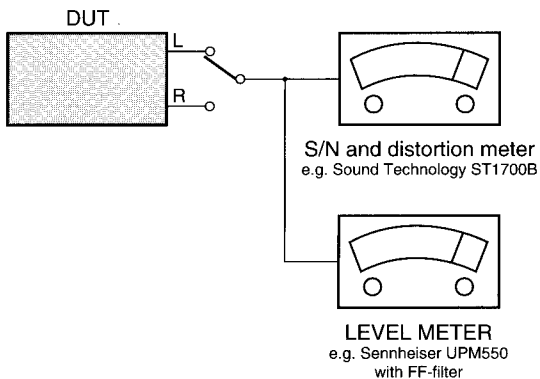
To avoid atmospheric interference all AM-measurements have to be carried out in a Faraday's cage. Use a bandpass filter (or at least a high pass filter with 250Hz) to eliminate hum (50Hz, 100Hz).

CD

Use Audio Signal Disc SBC429 4822 397 30184 (replaces test disc 3)

RECORDER

Use Universal Test Cassette **CrO₂** SBC419 4822 397 30069 or Universal Test Cassette **Fe** SBC420 4822 397 30071



RC5 SYSTEM/COMMAND CODES

Remote control key	System Code	Command Code
Standby	17, 18, 20	12
Stand by pressed longer than 1sec	00, 04, 05	12
Tuner	17	63
Tuning up	17	30
Tuning down	17	31
Preset up	17	32
Preset down	17	33
Preset 10 key	17	00-09
CD	20	63
CD Play	20	53
CD Stop	20	54
CD Pause	20	48
Preset 10 key	20	00-09
CD Next	20	32
CD Previous	20	33
CD Search forward	20	52
CD Search backward	20	50
CD Disc	20	30
Tape1	18	44
Tape2	18	46
Side	18	47
Tape Play	18	53
Tape Stop	18	54
Tape Wind	18	52
Tape Rewind	18	50
Tape Pause	18	48
Incredible Sound	16	64
DBB	16	70
DSC	16	79
Volume up	16	16
Volume down	16	17
Vocal Fader ¹⁾	16	67
Key control up ¹⁾	16	68
Key control down ¹⁾	16	69
Multi media	04	63

¹⁾ For sets with KARAOKE only

INDEX	4
Supplied accessories	
Demonstration mode	
Environmental information	
CONTROLS	5
INSTALLATION	6/7
Before you start ...	
Connections	
Speaker connections	
REMOTE CONTROL	7
BASIC FUNCTIONS	8
Switching the system on and off/standby	
Adjusting the display illumination	
System display and buttons	
Karaoke – microphone mixing	
SOUND CONTROLS	9
TUNER	10/11
Tuning to radio stations	
Programming radio stations (preset stations)	
Selecting a preset station	
RECORD TAPE ●	
Switchable tuning grid	
Programming a radio station name	
CD PLAYER	12/13
Playing a CD	
Changing the display time indication	
Selecting another track	
Searching for a passage during CD play	
Selecting another source during CD play	
RECORD TAPE ●	
REPEAT – repeating a track or the entire CD	
SHUFFLE – playing in random order	
Programming track numbers	
TAPE DECKS	14/16
Inserting a tape	
Playing a tape	
Fast winding	
Play mode	
Dolby B Noise Reduction System	
General information on recording	
Recording from a CD	
EDIT CD – automatic CD track selection by specifying the tape length	
Dubbing tapes	
RECORD TAPE ●	
CLOCK/TIMER	16/17
General	
Setting the clock	
Setting the timer for a radio recording	
Setting the timer for playback	
At the preset start time ...	
Reactivating/deactivating the timer	
MAINTENANCE	18
TECHNICAL DATA	18
TROUBLESHOOTING	19

Thank you for selecting this Philips system

This state-of-the-art mini stereo system offers you the latest technology, high quality sound and an extreme user-friendly operation thanks to its large display which contains advanced interactive user interface.

Supplied accessories

- 2 loudspeaker boxes, type LSB 650
- 2 loudspeaker cables
- Remote control
- Two batteries (AAA cells) for the remote control
- AC mains lead
- AM/MW frame aerial
- FM wire antenna 75 Ohms

Demo mode

The system has a demo mode, showing various features offered by the system.

- 1 To switch on the demonstration mode, press DEMO.
► The display demonstration starts with the message: "WELCOME TO THE AUDIO WORLD".
- 2 To leave the demonstration mode, press DEMO or POWER ON/STANDBY.

Environmental information

All unnecessary packaging material has been omitted. We have done our utmost to make the packaging easily separable into three mono-materials:

- cardboard (box)
- expandable polystyrene (buffer)
- polyethylene (bags, protective foam sheet)

Note: Your set consists of materials which can be recycled if disassembled by a specialized company. Please observe the local regulations regarding the disposal of packing materials, exhausted batteries and old equipment.

RTV servis Horvat

Kešinci, 31402 Semeljci

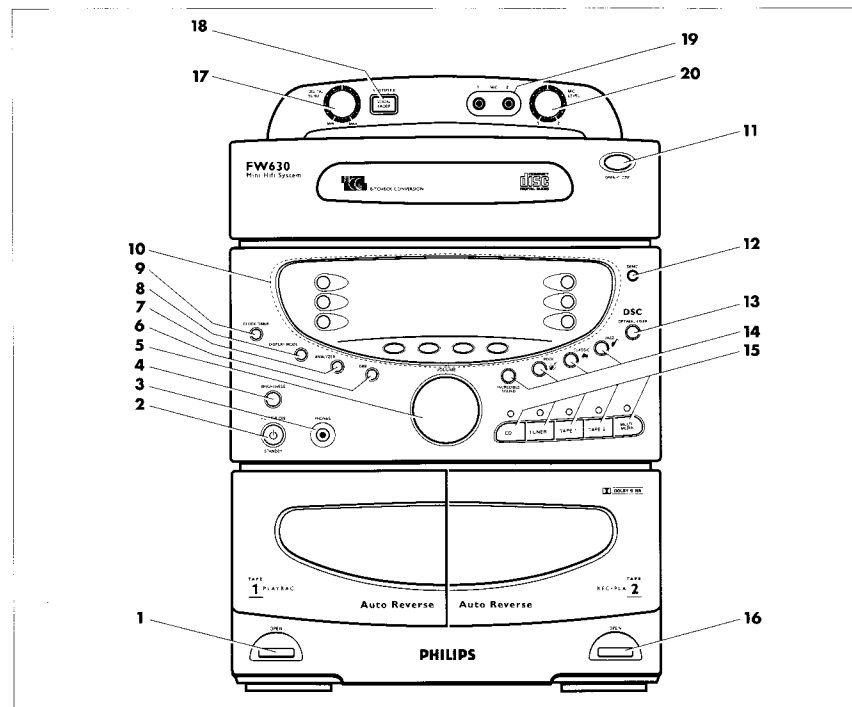
031-856-139

031-856-637

098-788-319

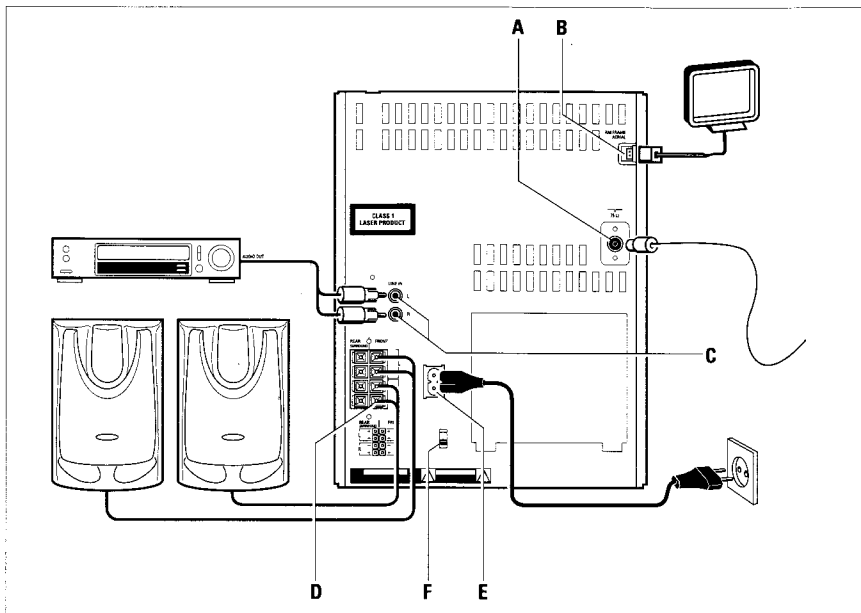
rtv-servis-horvat@os.tel.hr

Croatia



Top and front panel

- | | | | |
|---|---|---|--|
| 1 OPEN | to open the cassette compartment of deck 1 | 14 Digital sound control buttons: | |
| 2 POWER ON/STANDBY | to switch the set on and off | INCREDIBLE SOUND - ROCK - CLASSIC - JAZZ | to adjust the sound to your individual taste |
| 3 PHONES | 3.5 mm headphones socket | 15 Sound source selection buttons | |
| | <i>Inserting the plug will disconnect the speakers.</i> | CD | to select the CD player |
| 4 BRIGHTNESS | to adjust the intensity of the display illumination | TUNER | to select the tuner |
| 5 VOLUME | to adjust the volume level | TAPE 1 | to select the left tape deck |
| 6 DBB | D ynamic B ass B oost: to increase the bass level | TAPE 2 | to select the right tape deck |
| 7 ANALYZER | to switch the spectrum analyzer on and off | MULTIMEDIA | to select the multimedia mode (external sources, e.g. TV sound) |
| 8 DISPLAY MODE | to change the type of display information for the selected source | 16 OPEN | to open the cassette compartment of deck 2 |
| 9 CLOCK/TIMER | to select the clock/timer function | | |
| 10 System display and buttons | | Karaoke controls: | |
| 11 OPEN-CLOSE | to open and close the CD tray | 17 DIGITAL ECHO | to adjust the echo level for the microphone signals |
| 12 DEMO | to switch on and off the demonstration mode | 18 VOCAL FADER | to scroll between the different options to fade out the vocal of the original song |
| 13 OPTIMAL-USER Digital sound control/setting button | to select the desired equalizer setting:
OPTIMAL-USER 1-USER 2-OPTIMAL-... | 19 MIC | two 3.5 mm microphone sockets |
| | | 20 MIC LEVEL | to adjust the mixing level of the microphone signal |

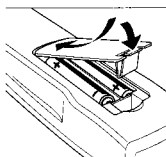


Before you start ...

- After unpacking the system, remove all protective material.
- **Before connecting the system to the mains**, check if the mains voltage as shown on the type plate corresponds to your local mains voltage. If it does not, consult your dealer or service organisation.
If your set is equipped with a voltage selector, set this selector to the local mains voltage.
The typeplate is located at the rear of the system.
- Place the system on a hard surface.
- Do not cover the vents and make sure that you leave sufficient room around the unit for ventilation.

Remote control:

- Open the battery compartment and insert the batteries supplied (type R03, UM-4 or AAA) as indicated.
- Remove the batteries if exhausted or if they will not be used again for a long period.

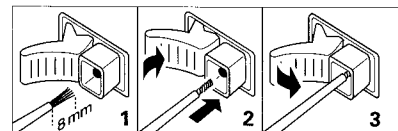


Connections

- A 75 Ω** – Socket for a FM antenna, 75 Ohms. Connect the supplied antenna wire with this socket. Find a position for best reception.
For good FM stereo reception, use an FM outdoor antenna or a connection to your house distribution system.
- B AM FRAME AERIAL** – Connector for the supplied AM frame antenna. Connect the plug of the AM frame antenna to this socket and position the frame antenna for optimum reception. Do not place the frame antenna too close to the units, the wires or the boxes, as this may cause unwanted noise.
- C LINE IN** – Input sockets (Left/Right) for connecting other sound sources (e.g. VCR, TV audio output etc.).
- D REAR/FRONT** – Terminals for four loudspeakers (see SPEAKER CONNECTIONS). Impedance of supplied loudspeakers is 6 ohms, if other front speakers are used, they should have at least 6 ohms.
- E MAINS** – Mains socket. After all other connections have been made, connect the mains lead to the MAINS socket and the wall socket.
- F 220-240V/110-127V** – Set this voltage selector to the local mains voltage. If the selector must be reset, disconnect the mains lead first.

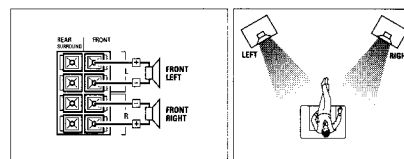
Speaker connections

You can connect the 2 supplied LSB 650 speakers or you can create a 4-speaker system for surround sound using two extra speakers having an impedance of at least 8 ohms, e.g. special surround-sound speakers, type PHILIPS SBC BS010.



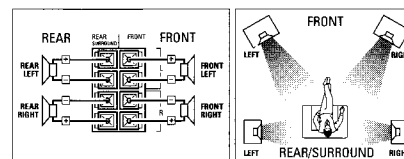
2-speaker system

- Connect the black or non-marked wires to the black terminals and the red or marked wires to the red terminals.



4-speaker system

- **Front speakers LSB 650 (8Ω):** Connect the black or non-marked wires to the black FRONT terminals and the red or marked wires to the red FRONT terminals.
- **Surround speakers, e.g. SBC BS010 (8Ω):** Connect the black or non-marked wires to the black REAR terminals and the red or marked wires to the red REAR terminals.



Positioning of the speakers

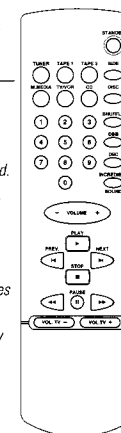
- You will find the best speaker position by experimenting. Placing the speakers on the floor will increase the bass response. Placing the speakers behind curtains, furniture etc. will reduce treble response and the stereo effect. You will obtain the ideal position when the two front speakers and the listening position build an equilateral triangle and the speakers are at ear-height.

Remote control functions

- Always first select the desired sound source and then press the required function key (for example CD + PLAY ► or TAPE + PLAY ►).

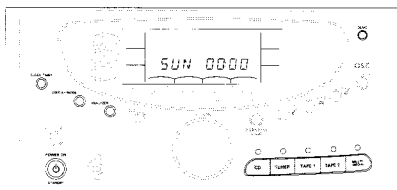
Notes:

- The remote control remains tuned to the selected sound source until another sound source button on the remote control is pressed.
- The corresponding LED indicator above the sound source buttons on the system flashes when its source is operated by the remote control.
- You can only control TV/VCR if this unit uses the RC-5 remote control system.
- Pressing TV/VCR will first switch on the TV set and after 1 sec the whole audio set. If TV/VCR is selected, the STANDBY button will first switch the TV set to standby and after 1 sec, the whole set.
- Pressing TV/VCR for more than 1 sec will select the external source that is connected via the LINE IN sockets.



- STANDBY** to switch the system to the standby mode
- TUNER - TAPE 1 - TAPE 2 - M.MEDIA - TV/VCR - CD** sound source selection buttons
- SIDE** **TAPE 1 or 2:** to select the front or back side of the tape (FRONT/BACK)
- DISC** **CD:** to select a CD (1-7) - not applicable to all versions
- SHUFFLE** **CD:** to switch on/off the shuffle feature
- DBB** to increase the bass level
- DSC** to select the desired sound setting:
ROCK-CLASSIC-JAZZ-OPTIMAL-USER 1-USER 2-ROCK-...
- INCREDIBLE SOUND** to switch on/off this sound feature
- Digits 0-9** (numbers consisting of two figures must be keyed in within 2 seconds)
CD: to key in a track number
TUNER: to key in a preset number
TV: to key in a TV station
- VOLUME - +** to adjust the volume level of the audio system
- PLAY ►** **CD, TAPE 1 or 2, VCR:** to start playback
◀ PREV/NEXT ▶ **TUNER:** to select a radio preset station
CD: to select the beginning of the current/previous or a subsequent track
TV: to select a TV preset station
- STOP ■** **CD, TAPE 1 or 2, VCR:** to stop playback
- ◀ ▶** **TUNER:** to tune to a radio station
CD: to search a particular passage
TAPE 1 or 2, VCR: to wind the tape
- PAUSE II** **CD, TAPE 1 or 2, VCR:** to interrupt playback
- VOL TV - +** **TV:** to adjust the volume

Switching on and off/standby



- **To switch on the unit,** press POWER ON/STANDBY on the unit or any sound source button on the unit or on the remote control.
 - The display illumination comes up with full intensity. The selected sound source is indicated on the display and the belonging LED indicator above the sound source button lights up.

- **To switch off the unit,** press POWER ON/STANDBY on the unit or on the remote control.
 - The system is in standby mode. The display illumination is half dimmed and the display shows the day and time.

- **To switch off the power supply,** remove the mains plug from the wall socket.

Notes:

- You can also switch on the set by pressing DISPLAY MODE, ANALYZER, CLOCK/TIMER or DEMO.

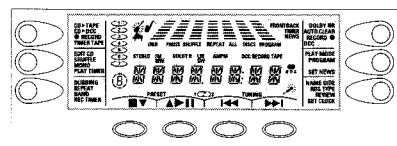
- The clock memory will be maintained for only ten minutes after the power supply is switched off.

Adjusting the display illumination

- You can change the intensity of the display illumination by pressing BRIGHTNESS.
 - When the system is switched on, the illumination switches from FULL INTENSITY→HALF INTENSITY→OFF→FULL ...
 - In standby mode, the illumination switches from HALF INTENSITY→OFF→HALF ... When the display is off, the power consumption is reduced to about 1 Watt.

Note: When switching on the system, the display always comes on with full intensity.

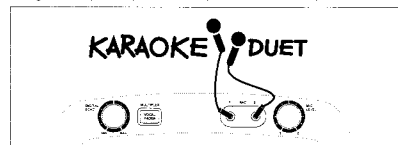
System display and buttons



When you select a sound source or the clock/timer mode, the functions available for the chosen source or the clock/timer mode light up in the display. Using the 10 buttons around the display field, you can select the desired function. These functions are explained in the appropriate chapters in detail.

KARAOKE – microphone mixing

Using a microphone you can mix your voice with any sound source:




- 1 To prevent acoustic feedback e.g. a loud howling sound, set the control MIC LEVEL to the minimum before you plug in the microphone.
- 2 Connect either 1 or 2 suitable microphones to the MIC sockets.
- 3 Select the desired sound source CD, TUNER, TAPE 1, TAPE 2 or MULTIMEDIA and start its playback.

- You can mix a digital echo with the signal of the microphones. Use the control DIGITAL ECHO to adjust the echo level for the desired effect. DIGITAL ECHO does not function in TUNER mode.


- Adjust the mixing ratio with the MIC LEVEL control.

- You can fade out the vocal on a **CD or a tape** in 4 different ways: Press VOCAL FADER several times until the desired option is displayed:

- **VOCAL FADER:** reduces/fades out the vocal of the original song.

- **AUTO VOCAL FADER:** reduces/fades out the vocal of the original song only for the time you use the microphone. The vocal is faded in again as soon as you stop singing. When (AUTO) VOCAL FADER is activated, this symbol (flashes) lights up in the display. 

- **MULTIPLEX** (for special KARAOKE CDs only!): suppresses the right channel (= vocal) of the KARAOKE CD. The music is audible on both channels.

- **AUTO MULTIPLEX** (for special KARAOKE CDs only!): suppresses the right channel (= vocal) only for the time you use the microphone. The music is audible on both channels. The vocal is faded in again as soon as you stop singing. When (AUTO) MULTIPLEX is activated, this symbol (flashes) lights up in the display. 

- **OFF:** The VOCAL FADER feature is switched off.

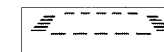
Notes:

- It is also possible to record the mixed signal. However, mixing is not possible in DUBBING mode (copying one tape to another).
- If you don't want to record via the microphone, unplug the microphone to avoid accidental mixing with the recording source.
- Due to the recording technique of some CDs it is unfortunately possible that the feature (AUTO) VOCAL FADER does not work.
- We do not recommend to use MULTIPLEX or AUTO MULTIPLEX with a conventional AUDIO CD. The music information would not be transmitted completely and you would only receive mono sound.

INCREDIBLE SOUND

- Additionally to all other sound settings, you can activate the incredible sound feature by pressing INCREDIBLE SOUND.
 - This creates a phenomenal surround sound effect even if the speakers are positioned close to the system. The sound becomes "incredibly" spatial.


The button lights up when the incredible sound feature is switched on.



ANALYZER – Spectrum Analyzer

The graph bars in the centre of the display show the sound levels. The spectrum analyzer shows continuously the frequency distribution of the current sound.

- By pressing the ANALYZER button, the spectrum analyzer bars are either hidden or shown.

→ The display shows either ANALYZER OFF or ANALYZER ON. 

Note: When switching on the system, the spectrum analyzer is always switched on.

DBB – Dynamic Bass Boost

- The bass response can be enhanced in 3 steps: every time you press the DBB button, the bass is enhanced even stronger or the DBB feature is switched off.

→ The display shows the selected DBB level:
DBB 1-DBB 2-DBB 3-DBB OFF-DBB 1-...

ROCK / CLASSIC / JAZZ

- Press ROCK, CLASSIC or JAZZ (or DSC on the remote control) to enhance the type of music you are listening to.

→ In the display the corresponding icon lights up. A realistic atmosphere for the selected style of music is created.

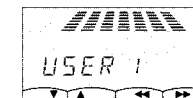
Switchable "OPTIMAL-USER" sound presets

- By repeatedly pressing OPTIMAL-USER, the display shows the different equalizer settings:
OPTIMAL-USER 1-USER 2-OPTIMAL-...

OPTIMAL: This equalizer setting is specially tuned to the acoustics of the supplied LSB 650 speakers.
USER 1 / USER 2: Here you have the possibility to set your individual sound or to listen to your own equalizer setting.

USER 1 / USER 2
Setting the equalizer

- 1 Press OPTIMAL-USER several times until the display shows USER 1 or USER 2.
 - The display function buttons light up and flash for 7 sec.



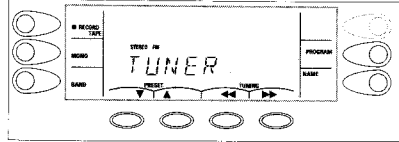
- 2 Use the display buttons ▼ ▲ and ◀ ▶ to adjust
 - bass (left two bars),
 - middle tones (middle three bars) and
 - treble (right two bars).
 - The graph bars change according to your settings.
 - If no button is pressed for 90 seconds, the sound setting mode is left automatically and the last changes are stored in the memory.

- 3 You can also leave the sound setting mode by pressing OPTIMAL-USER again.
 - The new sound setting is stored.

Note: From the moment the buttons ▼ ▲ and ◀ ▶ light up, you have got 7 sec to start adjusting the sound. If non of these buttons are pressed within 7 sec, the sound setting mode is left again.

Tuning to radio stations

- 1 Press TUNER on the unit or on the remote control.
 - First TUNER appears on the display and after a few seconds it will show the current frequency or the station name if available. The available display button functions light up.



- 2 Select the desired waveband by repeatedly pressing BAND.
- 3 Hold down TUNING ◀◀ or ▶▶ (◀◀ or ▶▶ on the remote control) until you approach the required frequency.
 - As long as the button is pressed, the digits on the display change according to the frequency.
 - As soon as you release the button, SEARCH appears on the display and the tuner searches the next station of sufficient strength. If the frequency has already been stored, the preset number is also displayed.

- 4 Press MONO to switch over to mono reception if there is interference noise caused by poor FM stereo reception.
 - Briefly MONO is displayed and the icon STEREO disappears.
 - When you switch back to stereo reception, the display will briefly show STEREO.
- 5 Repeat this procedure until you find the desired station.

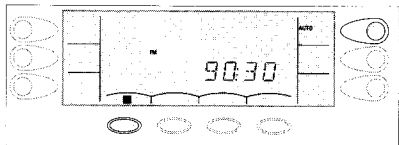
Note: If you briefly press TUNING ◀◀ or ▶▶ (◀◀ or ▶▶ on the remote control), the frequency changes step by step.

Programming radio stations (preset stations)

Automatic programming

30 radio stations can be stored automatically in the memory. This function will clear the old preset numbers. If less than 30 radio stations are found, the remaining preset numbers will not be changed.

- 1 Press TUNER on the unit or on the remote control.
- 2 Press PROGRAM to enter the programming mode.
- 3 Select the waveband by repeatedly pressing BAND.
- 4 Press AUTO to start the automatic programming.
 - The available display button functions light up and AUTO starts flashing.

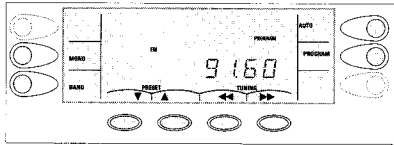


- The tuner automatically tunes to stations in the selected waveband. If less than 30 stations of sufficient strength are found, the tuner will stop.
 - The last newly stored preset number is automatically tuned in.
- To stop the automatic programming, press AUTO or ■.

Note: If you want to maintain some old presets, for example preset 1-9, select preset 10 before starting automatic programming; now only the presets 10 up to 30 will be programmed.

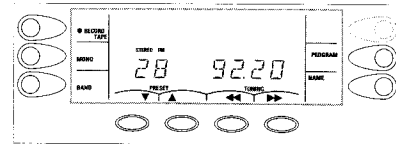
Manual programming

You can store up till 30 radio stations in the memory.

- 1 Press TUNER on the unit or on the remote control.
 - 2 Press PROGRAM to enter the programming mode.
 - The available display button functions light up and PROGRAM starts flashing.
- 
- 3 Select the waveband by repeatedly pressing BAND.
 - 4 Tune to the station to be programmed with TUNING ◀◀ or ▶▶ (or ◀◀ or ▶▶ on the remote control), as described earlier.
 - 5 If desired, switch over to FM mono reception by pressing MONO.
 - 6 Press PRESET ▲ or ▼ to allocate a number from 1 to 30 to the preset station (on the remote control use the buttons ◀◀ or ▶▶ or 0-9).
 - 7 Press PROGRAM to confirm the setting.
 - The frequency, preset number and stereo setting are now entered in the memory.

Note: When you store a new frequency, the radio station name belonging to the old frequency is also cleared.

Selecting a preset station



- Press PRESET ▲ or ▼ until the desired preset number appears on the display (on the remote control use the buttons ◀◀ or ▶▶ or 0-9).

RECORD TAPE ●

- 1 As soon as you press RECORD TAPE ●, the current sound will be recorded on TAPE 2, provided a tape suitable for recording is loaded.
- 2 To stop recording, press ■ (or STOP ■ on the remote control).

Switchable tuning grid (not on all versions)

In North and South America the frequency step between adjacent channels in the AM band is 10 kHz. In the rest of the world this step is 9 kHz. Usually the frequency step has been preset in the factory for your area.

In some versions the frequency step can be changed:

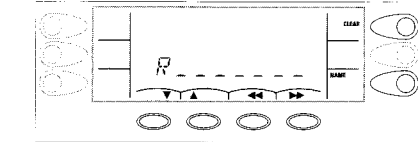
- Select AM by repeatedly pressing BAND.
- Keep the sound source button TUNER pressed for more than 5 sec.
 - The display shows either **GRID** ◀◀ or **GRID** ▶▶.

Programming a radio station name

You can assign a name of 8 characters to the preset stations.

- 1 First select the preset station by pressing PRESET ▲ or ▼ (on the remote control use the buttons ◀◀ or ▶▶ or 0-9).

- 2 Press NAME to enter the name programming mode.
 - The available display button functions light up and NAME starts flashing. A cursor flashes at the leftmost position.



- If a name is already assigned to the chosen preset station, this name will then be displayed.
- 3 Move the cursor to the left or right by pressing ◀◀ or ▶▶ (◀◀ or ▶▶ on the remote control).
 - 4 Select the desired character (A-Z, 0-9) by pressing ▲ or ▼ (on the remote control use the buttons ◀◀ or ▶▶).
 - 5 If your station name is correct, press NAME to store the name in the memory.

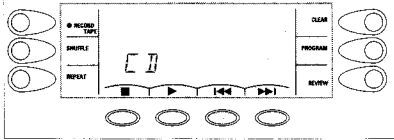
- You can erase a station name by pressing CLEAR.

- The display normally shows the radio station name if available. By repeatedly pressing DISPLAY MODE you can change the type of display information:
 - The display shows in turn: STATION NAME→FREQUENCY→STATION NAME...

Note: If the name programming mode is selected for more than 90 seconds without pressing ▲▼ or ◀▶, the last name will be recalled and the name programming mode will be left without storing any changes.

Playing a CD

- Press CD on the unit or on the remote control.
 - Briefly **CD** appears on the display. If there is no CD in the selected CD tray, the display will then show **NO DISC**. The available display button functions light up:

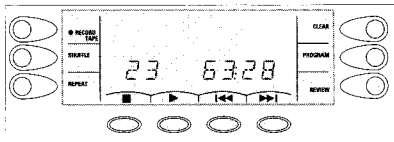


- Press OPEN-CLOSE on the unit to open the CD tray.
 - The display shows **OPEN**.

- Insert a CD, printed side up. Use only Digital Audio CDs. 8 cm CDs can be played as well.



- Close the tray by pressing OPEN-CLOSE.
 - The display shows **READING** and then the total number of tracks and the total playing time.



- Press **▶** (or **PLAY ▶** on the remote control) to start playback of the entire CD.
 - Playback starts with the first track. The display shows the current track number and its elapsed playing time.
 - When all tracks have been played, the CD player stops. The total number of tracks and the total playing time appear on the display.

- To stop CD play, press **■** (or **STOP ■** on the remote control).

- You can interrupt CD play by pressing **||** (or **PAUSE ||** on the remote control). Continue CD play by pressing **▶** (or **PLAY ▶** on the remote control).

Notes:

- You can also start CD play by selecting a track with the buttons 0-9 on the remote control.
- The tray will also close if you press **▶** or **SHUFFLE** or gently push against the CD tray.
- CD play also stops if you press **OPEN-CLOSE** or select another sound source.
- The system will switch off automatically, if no button is pressed for more than 15 minutes after CD play has finished.

Changing the display time indication

- During play, the display normally shows the elapsed playing time of the track currently played. You can change the type of the time information, by repeatedly pressing **DISPLAY MODE** on the unit.
 - The display shows in turn: **REMAINING TIME OF CURRENT TRACK** → **REMAINING TIME OF CD** → **ELAPSED TIME OF CURRENT TRACK** → ...

Selecting another track

- Briefly press **◀▶** or **▶▶** once/several times to skip to the beginning of the current/previous or subsequent track (on the remote control use the buttons **◀▶** or **▶▶** or 0-9).
 - The display shows the selected track number.
 - During play: CD play continues automatically with the selected track.
 - In the stop position: press **▶** to start CD play.

Searching for a passage during CD play

- Hold down **◀▶** or **▶▶** (or **◀▶** or **▶▶** on the remote control) to find a particular passage in the forward or backward direction.
 - The volume is automatically reduced to a low level.

- Release the button when you have reached the desired passage.

Note: In the shuffle mode and when playing a program, searching is only possible within the playing track.

Selecting another source during CD play

- You can select another sound source during CD play. If you select the CD source again, the CD player will return to the original mode: **PLAY**, **SHUFFLE**, **REPEAT** or **PROGRAM**.
 - CD play will resume at the position where it was interrupted.

Note: CD play cannot be resumed if the unit has been switched to standby in the meantime.

RECORD TAPE ●

- As soon as you press **RECORD TAPE ●**, the current CD-sound will be recorded on TAPE 2, provided a tape suitable for recording is loaded.
- To stop recording and CD play, press **■** (or **STOP ■** on the remote control). If you only want to stop recording, press **TAPE 2** first, and then press **■**.

REPEAT – repeating a track or the entire CD

- Press **REPEAT** on the unit several times until the desired option is displayed:

REPEAT: The current track is played repeatedly.
REPEAT ALL: The entire CD (or program) is played repeatedly.

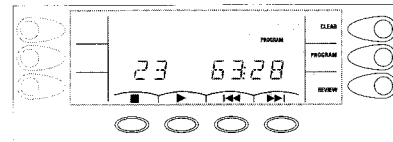
- During play: The selected repeating mode is automatically executed.
- In the stop position: press **▶** to start CD play.

- To return to normal CD play, press **REPEAT** until all related indications (**REPEAT ALL**) disappear from the display.

Programming track numbers

You may select a number of tracks and store these in the memory in the desired sequence. You may store any track more than once. At most, 20 tracks can be stored in the memory. The display will show the message **PROGRAM FULL**, if you exceed the maximum of 20 tracks.

- Press **PROGRAM** to enter the CD programming mode.
 - The available display button functions light up and **PROGRAM** starts flashing:



- Select the desired track by pressing with **◀▶** or **▶▶** (or **◀▶** or **▶▶** or 0-9 on the remote control).

- As soon as the desired track is displayed, press **PROGRAM** to store the track.
 - The display shows the total number of stored tracks, followed by the just stored track number. **PROG** behind the track number indicates, this track number is stored.

- Select and store in this way all desired tracks.

- Quit the CD programming mode by pressing **■** (or **STOP ■** on the remote control) or immediately start playback of the program by pressing **▶** or **SHUFFLE** (or **PLAY ▶** or **SHUFFLE** on the remote control).

Note:

You can also program a sequence of tracks while playing a CD.

SHUFFLE – playing in random order

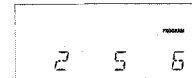
- Press **SHUFFLE** on the unit or on the remote control before or during playback.
 - The display shows **SHUFFLE**, all the tracks will now be played in a random order.

- To return to normal CD play, press **SHUFFLE** on the unit (or on the remote control).

Note: You can combine some of the REPEAT and SHUFFLE features at the same time and for example repeatedly play the entire CD or program in random order (SHUFFLE REPEAT ALL).

Reviewing your settings

- You can review your settings by pressing **REVIEW**.
 - The display shows in bundles of three all stored track numbers. During CD play only the tracks that still have to be played are shown on the display.



Note: If you press REVIEW when no program is available, the message NO PROGRAM will appear on the display.

Clearing the entire program (in the stop position)

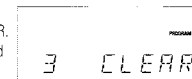
- Press **CLEAR** to clear the program.
 - On the display **PROGRAM CLEAR** briefly lights up and the flag **PROGRAM** disappears.

Note: The program will also be cleared if you interrupt the power supply or open the CD tray.

Clearing a track from a program

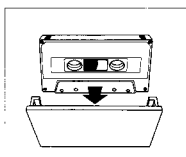
- Press **PROGRAM** to enter the CD programming mode.
- Select the track to be cleared by pressing **◀▶** or **▶▶** (or **◀▶** or **▶▶** on the remote control).

- As soon as the number you wish to clear is displayed, press **CLEAR**.
 - The cleared track number and **CLEAR** appear briefly.



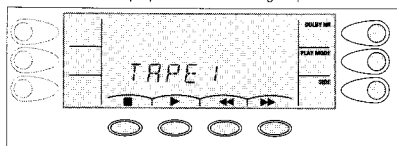
Inserting a tape

- 1 Press OPEN to open the cassette compartment.
 - The display shows 000.
 - The deck detects the presence of a tape in the cassette compartment and automatically selects the tape type (NORMAL or CrO₂).



Playing a tape

- 1 Press TAPE 1 or TAPE 2 on the unit or on the remote control.
 - Briefly TAPE 1 or TAPE 2 appears on the display.
 - The available display button functions light up:



- 2 Insert a recorded tape with the open side down.
- 3 Select the tape side by pressing SIDE on the unit (or on the remote control) several times until the desired indicator lights up:
 - FRONT: the visible side will be played.
 - BACK: the invisible backside will be played.
 - The tape counter is set to 000.

- 4 If desired, switch on the Dolby NR system by pressing DOLBY NR.

- 5 Press ► (or PLAY ► on the remote control) to start playback.
 - The display shows the tape counter.



- 6 Press ■ (or STOP ■ on the remote control) if you want to stop playback before the end of the tape.



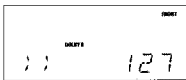
Notes:
- You can set the tape counter to 000 by pressing SIDE twice.

- If no button is pressed for more than 15 minutes after playback has finished, the system automatically switches off.

Fast winding

During playback

- 1 Hold down ◀◀ or ▶▶ (or ◀◀ or ▶▶ on the remote control) to find a particular passage in the forward or backward direction.
 - The volume is automatically reduced to a low level.



- 2 Release the button when you have reached the desired passage.

In the stop position

- 1 Briefly press ◀◀ or ▶▶ (or ◀◀ or ▶▶ on the remote control).
- 2 Stop winding by pressing ■ (or STOP ■ on the remote control).

Play mode

- You can select the playback mode by pressing PLAY MODE several times until the desired indicator lights up:

- ◀ to play (record) one side. At the end of the first side the recorder stops.
- ↔ to play (record) both sides once. At the end of the first side, the tape direction is reversed and the recorder stops at the end of the second side.
- ∞ for non-stop playback. The deck reverses the tape direction (up to ten times) whenever reaching the end of the tape side. To stop, press ■.

- 2 for non-stop playback on both decks: The deck reverses the tape direction (up to ten times on each deck) when reaching the end of the tape side. Playback of both tape sides rotates between deck 1 and deck 2. To stop, press ■.

Note: For a recording only the play modes ▶ and ↔ are available.

Dolby B Noise Reduction System

The Dolby B NR System is manufactured under license from Dolby Laboratories Licensing Corporation. The word Dolby and the DD symbol are trademarks of Dolby Laboratories Licensing Corporation.

- Switch the Dolby B NR on and off with the DOLBY NR button.

Notes:
- A tape recorded with the Dolby B NR system should also be played in the Dolby B NR mode. If you forget to operate the DOLBY NR button, the treble may be reproduced too strongly or too faintly.

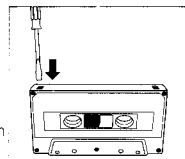
- Dolby NR button has no influence during dubbing (copying from TAPE 1 to TAPE 2). An original tape recorded with Dolby B NR automatically produces a copy with Dolby B NR.

General information on recording

- Recording is permissible insofar as copyright or other rights of third parties are not infringed.
- At the very beginning and end of the tape, no recording will take place during the 7 seconds when the leader tape passes the recorder heads.
- When a recording is active, most functions are disabled. RECORDING ACTIVE will appear on the display when a wrong button is pressed.
- In general, the recording level is set automatically. The recording is not affected by the controls VOLUME, DBB, INCREDIBLE SOUND, ROCK, CLASSIC, JAZZ and OPTIMAL-USER.

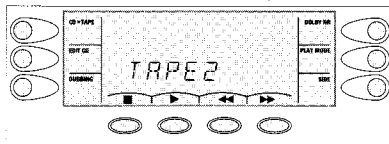
Protecting tapes against accidental erasure

- Keep the tape side to be safeguarded in front of you and break out the left tab. Now, recording on this side is no longer possible.
- To render this safeguard ineffective, cover the aperture with a piece of adhesive tape.



Recording from a CD

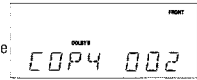
- 1 Insert a CD and, if desired, program track numbers.
- 2 Press TAPE 2 on the unit or on the remote control.
 - The available display button functions light up:



- 3 Insert a blank tape into TAPE 2.
- 4 Select the tape side by pressing SIDE: FRONT or BACK.
- 5 Select the play mode by pressing PLAY MODE until the desired indicator lights up: ▶ or ↔.
- 6 If desired, switch on the Dolby NR system by pressing DOLBY NR.
- 7 If you want to make a "EDIT CD recording", follow from here the instructions for EDIT CD.

- 8 Start the recording by pressing CD ►TAPE.

- The display shows COPY.
- With a delay of 7 sec (leader tape of the tape), playing of the CD or program starts automatically. At the end of the first side, recording stops somewhere within the running track.
- When ◀◀ is selected, the tape direction is reversed and recording continues with the beginning of the incompletely recorded track.
- Recording will stop when it's finished according to the chosen play mode or when the CD player reaches the end of the CD or the program.

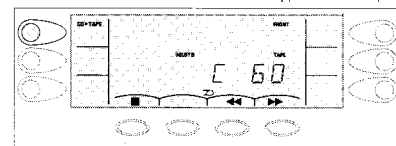


- Press ■ (or STOP ■ on the remote control) to stop the recording at an earlier stage.

EDIT CD – automatic CD track selection by specifying the tape length

To prevent that at the end of the tape the recording is interrupted somewhere within a track, you can use the EDIT CD feature. However, it can only be used for CDs with a maximum of 30 tracks. The unit automatically selects the total number of tracks that will fit onto each tape side. The original order of tracks will not be changed.

- 1 Press EDIT CD.
 - SELECT TAPE LENGTH and C60 appear on the display.



- 2 Press ◀◀ or ▶▶ until the desired tape length appears on the display (on the remote control use the buttons ◀◀ or ▶▶).
 - The display shows in turn: C60-C90-C 100-C 120-C30-C45-C60-...

- 3 Start the recording by pressing CD ►TAPE.
 - With a delay of 7 sec (leader tape of the tape), playing of the CD or program starts automatically.
 - Recording will stop when it's finished according to the chosen play mode or when the CD player reaches the end of the CD or the program.

- Press ■ (or STOP ■ on the remote control) to stop the recording at an earlier stage.

- You can change the type of the CD time information, by repeatedly pressing DISPLAY MODE on the unit:
 - The display shows in turn: REMAINING TIME OF CURRENT TRACK – REMAINING TIME OF CURRENT TAPE SIDE – ELAPSED TIME OF CURRENT TRACK – ...

Dubbing tapes (copying from TAPE 1 to TAPE 2)

- Insert a recorded tape into deck 1 and a blank tape into deck 2.
 - Press TAPE 1 and prepare the deck for the recording:
 - Select the tape side by pressing SIDE: FRONT or BACK.
 - Select the play mode by pressing PLAY MODE until the desired indicator lights up: \square or \square .
 - Press TAPE 2 and select the tape side by pressing SIDE: FRONT or BACK.
 - Press DUBBING and thereafter select the dubbing speed by pressing \blacktriangleleft or \blacktriangleright :
 - The display shows *NORMAL* (normal speed) or *FAST* (high speed). During high-speed dubbing, the sound is reduced to a low volume.
 - Start recording by pressing DUBBING.
 - Both decks start running and either *NORMAL* or *FAST* appears.
 - Recording will stop when one or both sides of the tape are full (depending on the chosen play mode).
- Press \blacksquare (or STOP \blacksquare on the remote control) to stop the recording at an earlier stage.

Notes:

- *PRESS STOP FIRST will light up if you press SIDE: you cannot reverse the playback direction during dubbing.*

- *During dubbing you can listen to any other sound source.*

RECORD TAPE ●

- As soon as you press RECORD TAPE ●, the current sound (CD, TUNER, TAPE 1 or MULTIMEDIA) will be recorded on TAPE 2.

Erase an old tape by recording a silence:

Select CD without starting CD play and press RECORD TAPE ●.

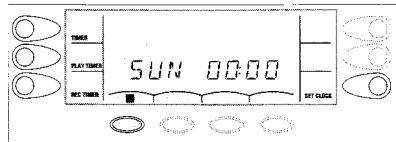
- To stop recording, press \blacksquare .

General

The display shows the weekday and the time. The clock display will flash and has to be set

- when you first plug the unit into the mains, or
- if the power supply was interrupted for longer than 10 minutes.

- Press CLOCK-TIMER to enter the clock/timer mode.
 - The clock/timer display with its available display button functions appears:



- To leave the timer display, press \blacksquare , CLOCK-TIMER, POWER ON/STANDBY or any sound source selection button.

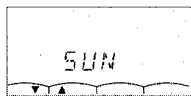
Notes:

- *The clock and the timer cannot be set with the remote control.*

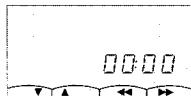
- *If no button is pressed for more than 90 seconds, the clock setting mode is left automatically without storing the last changes.*

Setting the clock

- Press CLOCK-TIMER to enter the clock/timer mode.
 - The clock/timer display as shown above appears.
- Press SET CLOCK to enter the clock setting mode.
 - The function indicator SET CLOCK starts flashing.
- Select the day by pressing \blacktriangle or \blacktriangledown until the correct day is indicated.



- Confirm the day by pressing SET CLOCK.
 - The hour and the minute digits appear.



- Adjust the hours by using \blacktriangle and the minutes by using \blacktriangleleft and \blacktriangleright .
 - When pressing the buttons briefly, the digits will change step-by-step. By pressing longer, the running speed will increase after a few seconds.
- Press SET CLOCK to store the setting and to leave the clock setting mode.
 - The clock starts running.

Setting the timer for a radio recording

- Insert a tape into TAPE 2.
- Press CLOCK-TIMER to enter the clock/timer mode.
 - The clock/timer display appears.
- Press REC TIMER to enter the timer setting mode.
 - The function indicator REC TIMER starts flashing and a radio preset appears.
- Press \blacktriangle or \blacktriangledown until the desired preset station is indicated.
- Confirm the preset station by pressing REC TIMER.
 - The message *ON* and the time appear.
 - The **recording start time** must be entered.
- Adjust the hours and the minutes by using \blacktriangle and \blacktriangleleft .
- Confirm the start time by pressing REC TIMER.
 - The message *OFF* and the time appear.
 - The **recording stop time** must be entered.
- Adjust the hours and the minutes by using \blacktriangle and \blacktriangleleft .
- Press REC TIMER to confirm the settings and to leave the timer setting mode.
 - The timer is activated and TIMER lights up on the display.

**Setting the timer for playback**

- Press CLOCK-TIMER to enter the clock/timer mode.
 - The clock/timer display appears.
- Press PLAY TIMER to enter the timer setting mode.
 - The function indicator PLAY TIMER starts flashing and the last selected timer sound source appears.
- Press \blacktriangle or \blacktriangledown until the desired sound source is indicated.
- Confirm your selection by pressing PLAY TIMER.
 - If you have selected TUNER, press \blacktriangle or \blacktriangledown to select the desired preset station.
 - If you have selected CD, insert a CD.
 - If you have selected TAPE, insert a tape into the cassette compartment.
- Confirm your selection by pressing PLAY TIMER.
 - The message *ON* and the time appear.
 - The **start time** must be entered.
- Adjust the hours and the minutes by using \blacktriangle and \blacktriangleleft .
- Press PLAY TIMER to confirm the settings and to leave the timer setting mode.
 - The timer is activated and TIMER lights up on the display.

At the preset start time ...

- The power is turned on or, if another sound source is selected, the set switches to the preset source. The preset source comes on automatically.
- 15 minutes after playback of the CD or the tape has finished, the system switches to standby. If the timer is activated with the TUNER mode, the sound remains on until you switch off the system.

Notes:

- *If the set was activated from standby mode and no button is pressed for more than 40 minutes, the power is turned off again.*

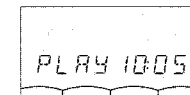
- *If there is the same start time for REC TIMER and PLAY TIMER, the REC TIMER will be activated.*

- *If you are recording at the time the timer is activated, the timer function will be cancelled.*

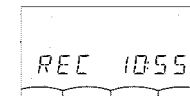
Reactivating/deactivating the timer

- Press CLOCK-TIMER to enter the clock/timer mode.
 - The clock/timer display appears.
- To switch off or to reactivate a timer function, press TIMER several times until the required indication appears:

- PLAY* (playback) and the programmed start time for activating the PLAY TIMER.



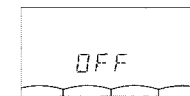
- REC* (recording) and the programmed start time for activating the REC TIMER.



- BOTH ON* - both PLAY TIMER and REC TIMER are activated.



- OFF* for switching the timer off.



Warnings & Safety

(GB) WARNING

All ICs and many other semiconductors are susceptible to electrostatic discharges (ESD). Careless handling during repair can reduce life drastically.

When repairing, make sure that you are connected with the same potential as the mass of the set via a wrist wrap with resistance. Keep components and tools at this potential.

(F) ATTENTION

Tous les IC et beaucoup d'autres semi-conducteurs sont sensibles aux décharges statiques (ESD). Leur longévité pourrait être considérablement écourtée par le fait qu'aucune précaution n'est prise à leur manipulation.

Lors de réparations, s'assurer de bien être relié au même potentiel que la masse de l'appareil et enfilier le bracelet servi d'une résistance de sécurité.

Veiller à ce que les composants ainsi que les outils que l'on utilise soient également à ce potentiel.

ESD



(D) WARNUNG

Alle ICs und viele andere Halbleiter sind empfindlich gegenüber elektrostatischen Entladungen (ESD). Unvorsichtige Behandlung im Reparaturfall kann die Lebensdauer drastisch reduzieren.

Sorgen Sie dafür, daß sie im Reparaturfall über ein Pulsarmband mit Widerstand mit dem Massepotential des Gerätes verbunden sind.

Halten Sie Bauteile und Hilfsmittel ebenfalls auf diesem Potential.

(NL) WAARSCHUWING

Alle IC's en vele andere halfgeleiders zijn gevoelig voor electrostatische ontladingen (ESD).

Onzorgvuldig behandelen tijdens reparatie kan de levensduur drastisch doen verminderen. Zorg ervoor dat u tijdens reparatie via een polsband met weerstand verbonden bent met hetzelfde potentiaal als de massa van het apparaat.

Houd componenten en hulpmiddelen ook op ditzelfde potentiaal.

(I) AVVERTIMENTO

Tutti IC e parecchi semi-conduttori sono sensibili alle scariche statiche (ESD).

La loro longevità potrebbe essere fortemente ridotta in caso di non osservazione della più grande cauzione alla loro manipolazione. Durante le riparazioni occorre quindi essere collegato allo stesso potenziale che quello della massa dell'apparecchio tramite un braccialetto a resistenza.


Assicurarsi che i componenti e anche gli utensili con quali si lavora siano anche a questo potenziale.

SAFETY




(GB) SAFETY

Safety regulations require that the set be restored to its original condition and that parts which are identical with those specified be used.

Safety components are marked by the symbol .

(D) SAFETY

Bei jeder Reparatur sind die geltenden Sicherheitsvorschriften zu beachten. Der Originalzustand des Gerätes darf nicht verändert werden. Für Reparaturen sind Originalersatzteile zu verwenden. Sicherheitsbauteile sind durch das Symbol  markiert.


(S) Varning !

Osynlig laserstrålning när apparaten är öppnad och spårren är urkopplad. Betrakta ej strålen.


(F) SAFETY

"Pour votre sécurité, ces documents doivent être utilisés par des spécialistes agréés, seuls habilités à réparer votre appareil en panne".

(I) SAFETY

Le norme di sicurezza estigono che l'apparecchio venga rimesso nelle condizioni originali e che siano utilizzati i pezzi di ricambio identici a quelli specificati. Componenti di sicurezza sono marcati con .

(F) SAFETY


Les normes de sécurité exigent que l'appareil soit remis à l'état d'origine et que soient utilisées les pièces de rechange identiques à celles spécifiées. Les composants de sécurité sont marqués .

(DK) Advarsel !

Usynlig laserstrålning ved åbning når sikkerhedsafbrydere er ude af funktion. Undgå udsættelse for strålning.

(NL) SAFETY

Veiligheidsbepalingen vereisen, dat het apparaat in zijn oorspronkelijke toestand wordt teruggebracht en dat onderdelen, identiek aan de gespecificeerde, worden toegepast.

De Veiligheidsonderdelen zijn aangeduid met het symbool .

(FIN) Varoitus !

Avatussa laitteessa ja suojalukituksen ohitettaessa olet alltiina näkymättömälle laserisäteilylle. Älä katso säteeseen !

SERVICE HINTS

Service Tools

TORX screwdriver set SBC 163	4822 295 50145
Audio signal disc SBC 429	4822 397 30184
Test disc 5 (disc without errors) +	
Test disc 5A (disc with dropout errors, black spots and fingerprints)	
SBC 426/426A	4822 397 30096
Burn in test disc (65 min. 1kHz signal at -30dB level without "pause")	4822 397 30155
Universal test cassette Fe SBC 420	4822 397 30071
Universal test cassette CrO2 SBC 419	4822 397 30069

RTV servis Horvat

Kešinci, 31402 Semeljci

031-856-139

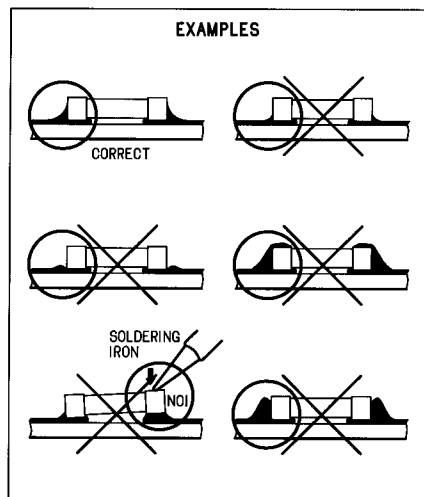
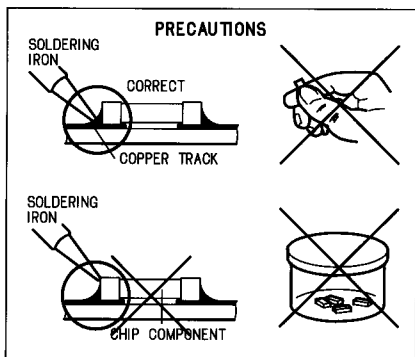
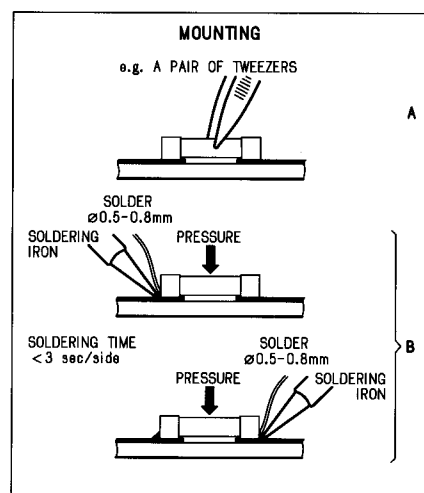
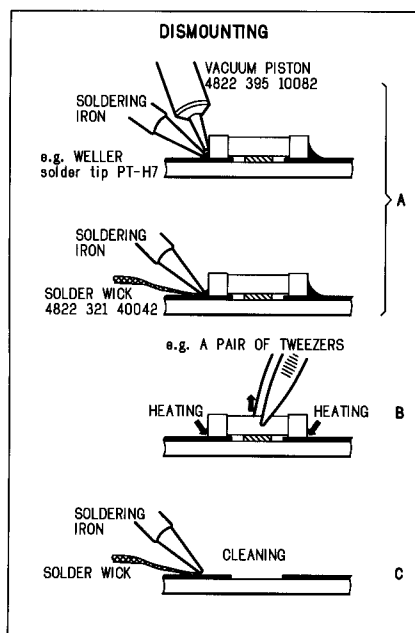
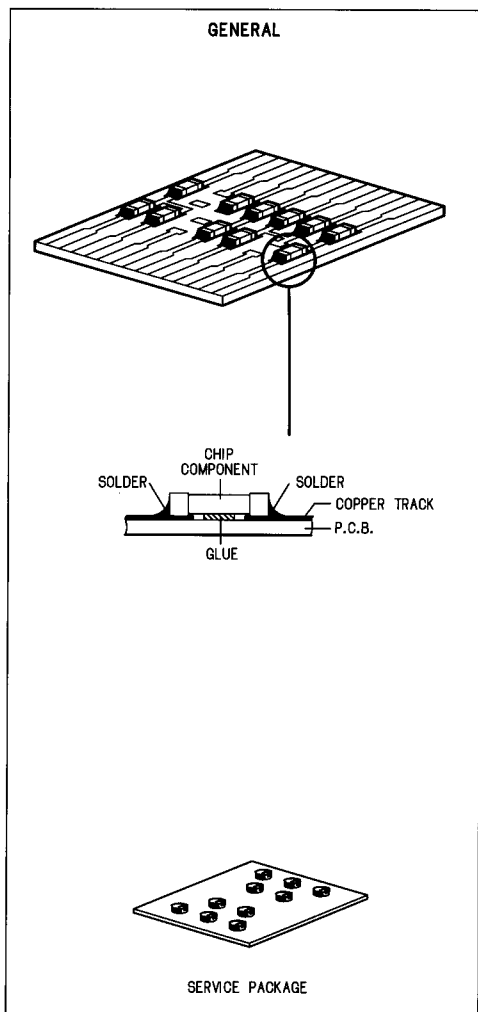
031-856-637

098-788-319

rtv-servis-horvat@os.tel.hr

Croatia

Handling Chip Components



DISMANTLING INSTRUCTIONS

Dismantling of Cassette flap

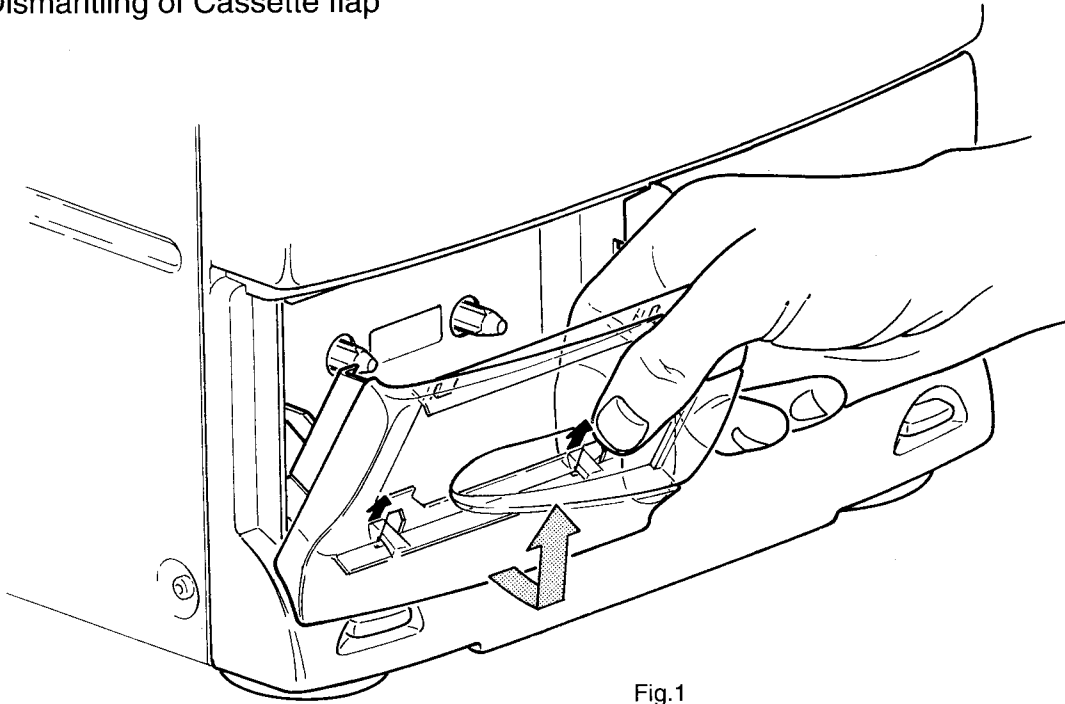


Fig.1

Dismantling the Karaoke Top (not on all Versions)

- 1) Release the two snaps on back side
- 2) Lift the back side of the cover first

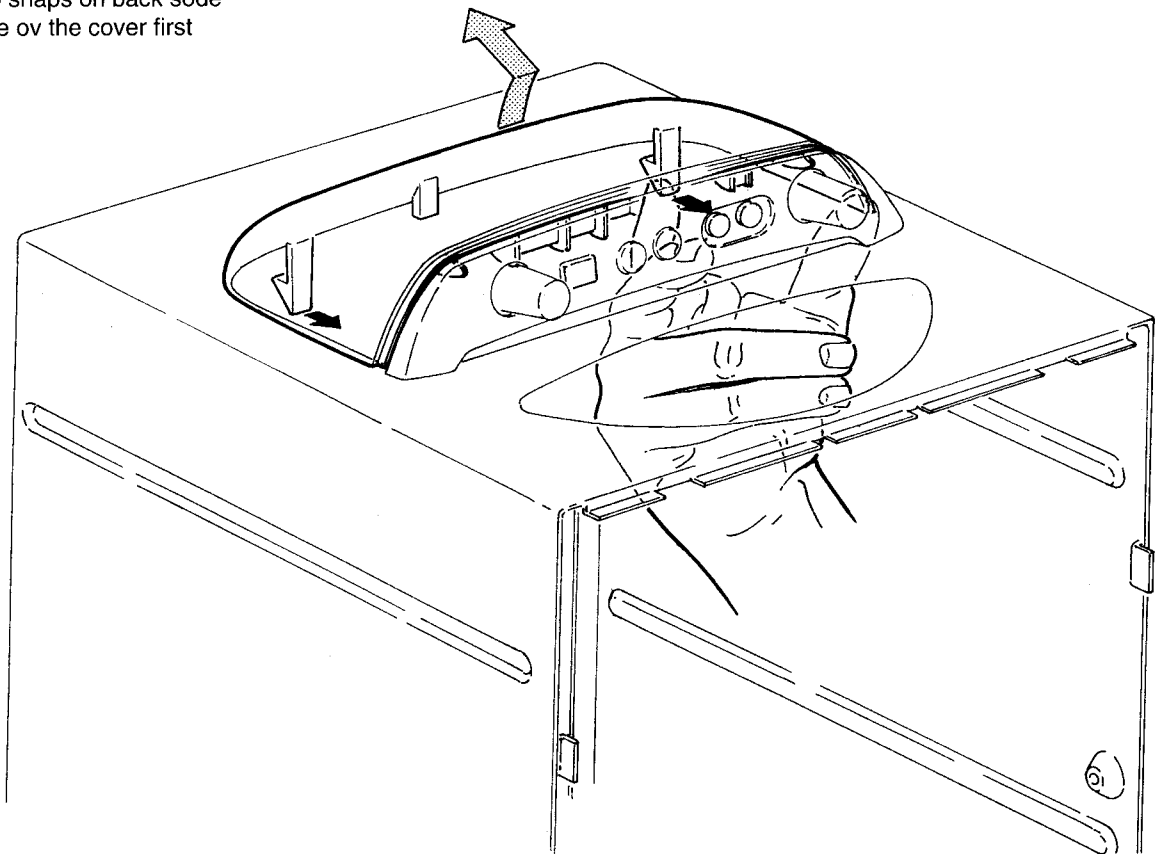
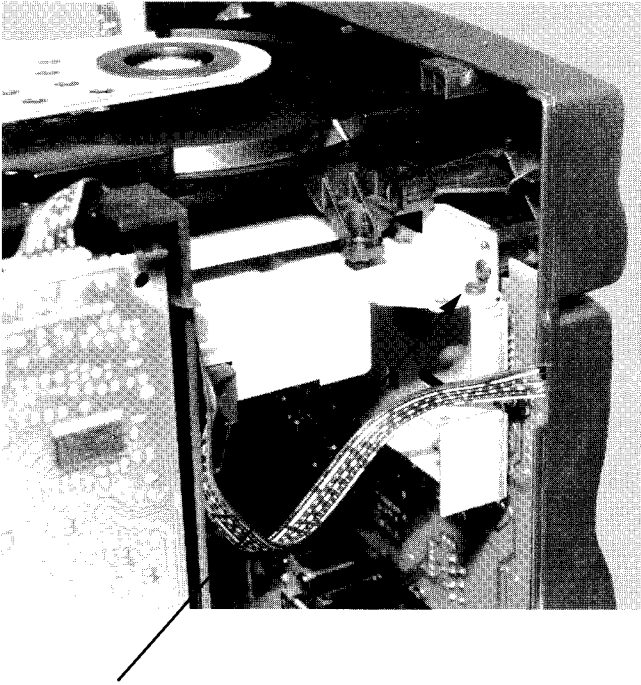


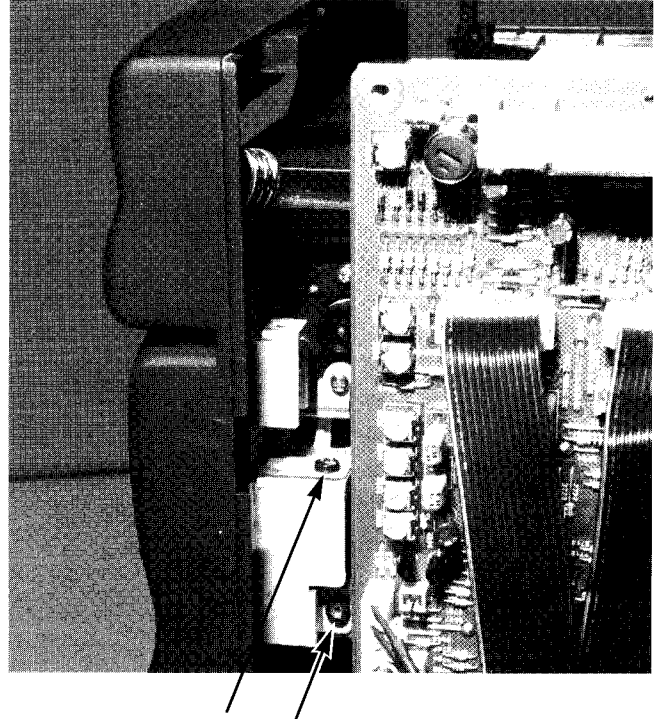
Fig.2

Dismantling of Front

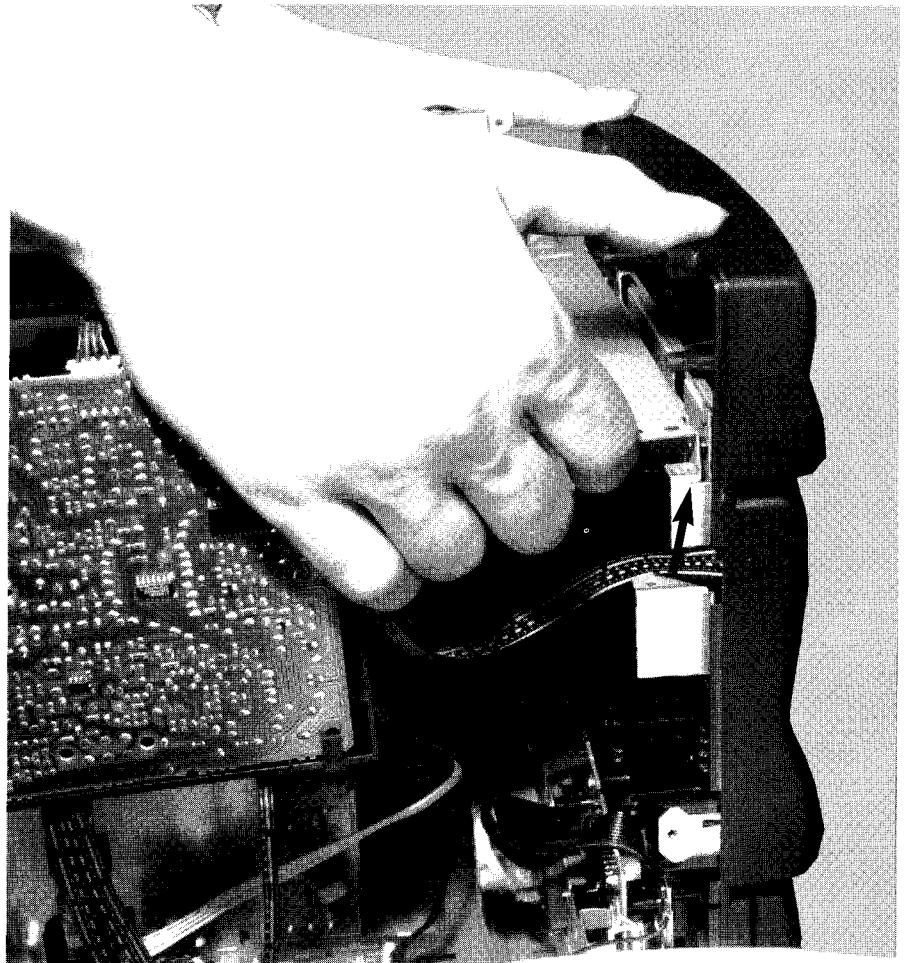
- 1) Remove top cover.
- 2) Loosen 3x screw on bottom.



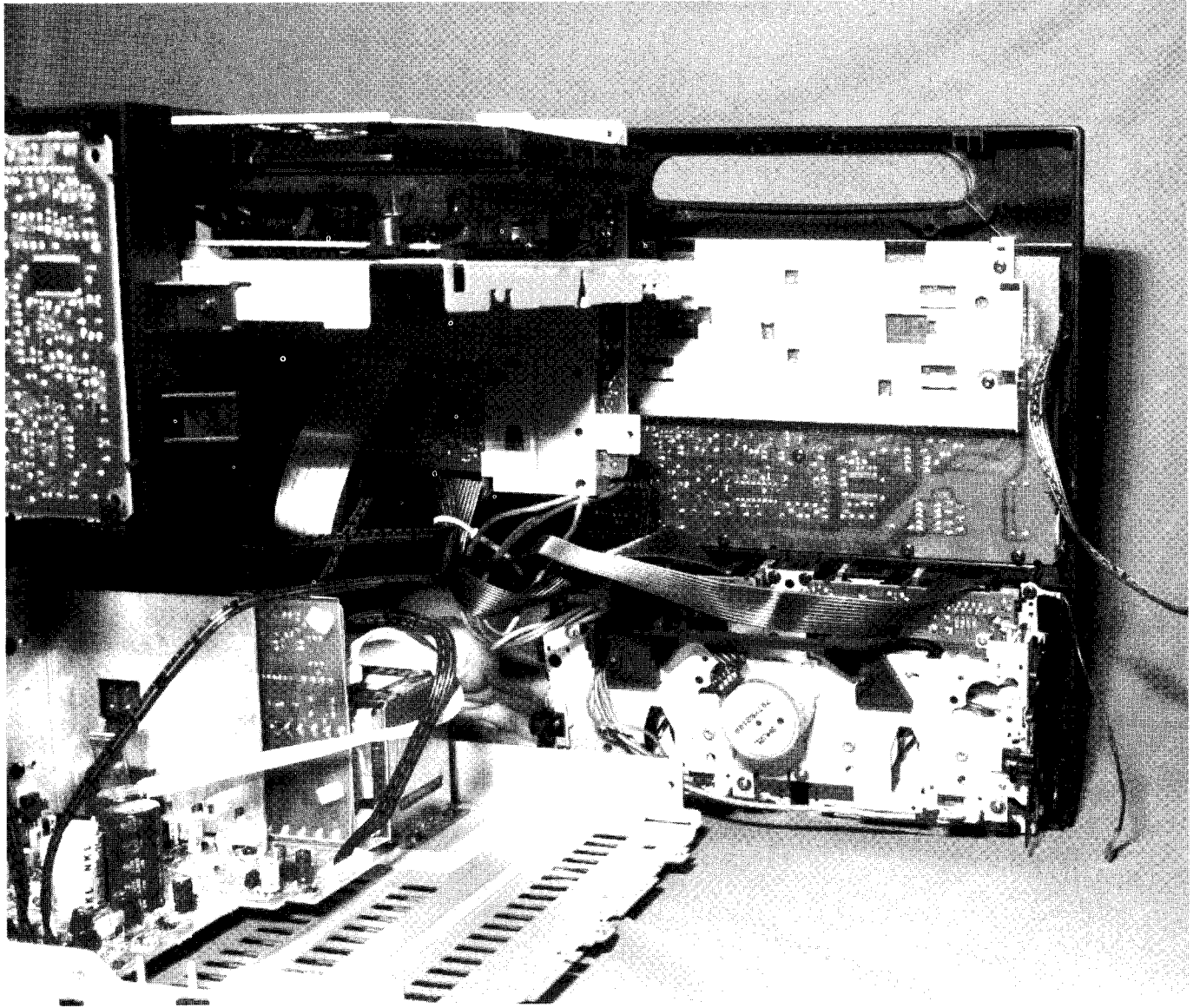
- 3) Loosen screw on metal bracket



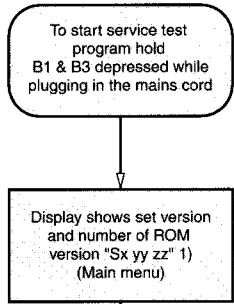
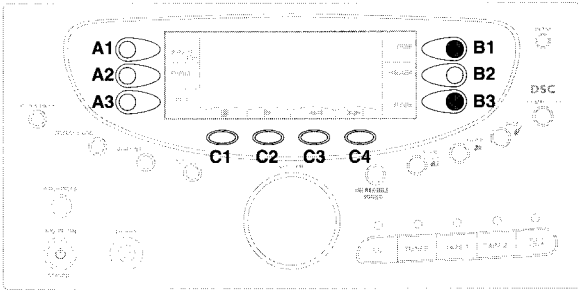
- 3) Loosen 2x screw on metal bracket
- 4) Lift the CD Module to release the metal bracket as shown in picture below.



- 5) Turn the front sideways as shown below.



SERVICE TEST PROGRAM



- 1) S stands for Service Testprogram
- S1 stands for sets with CD
- S2 stands for sets with CD Changer and RDS
- S3 stands for sets with CD Changer without RDS
- yy stands for software version number of μP on Front Board (counted from 99 downwards)
- zz stands for software version number of μP on Combi Board (counted from 99 downwards)

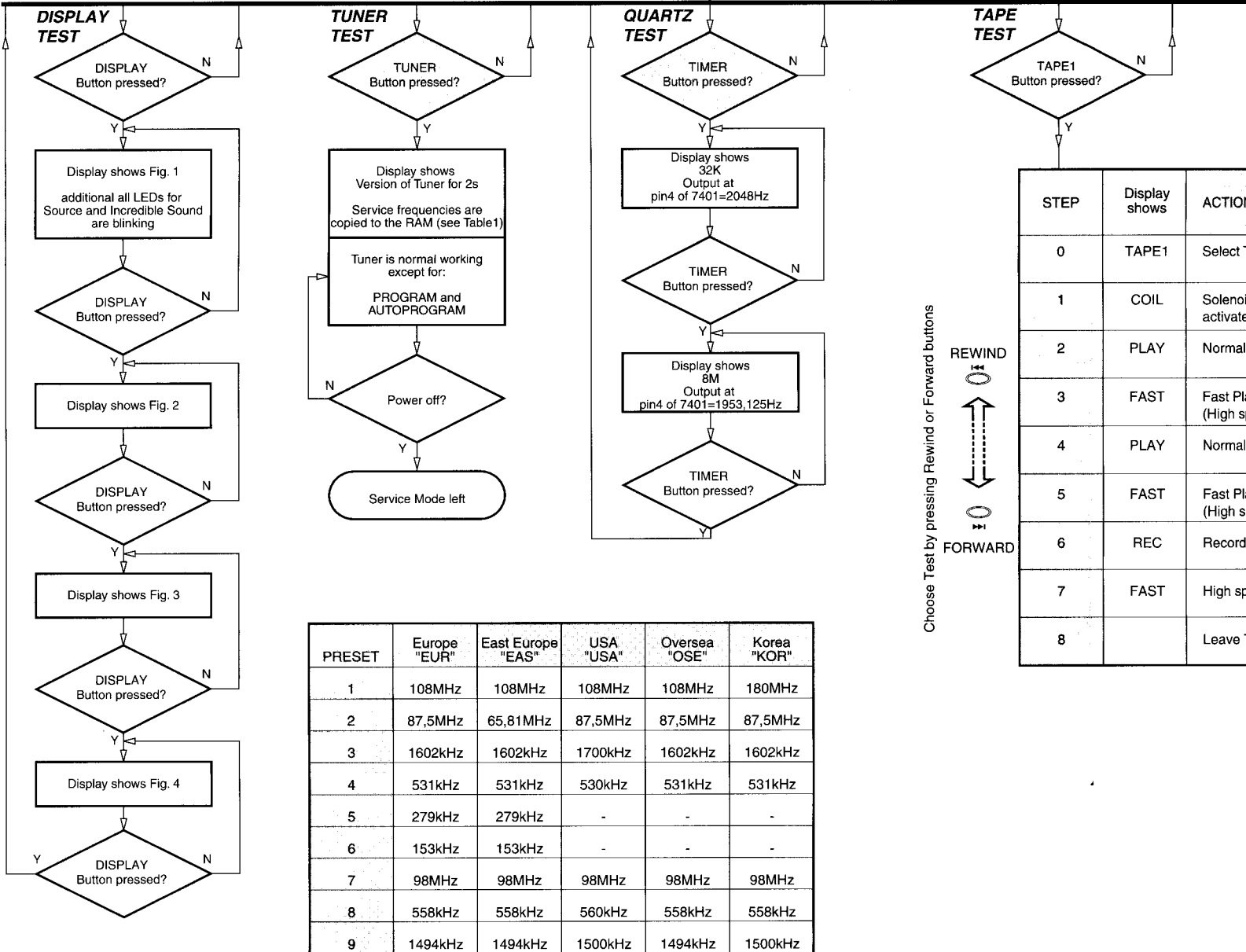


Table 1

STEP	Display shows	ACTION
0	TAPE1	Select T
1	COIL	Solenoid activate
2	PLAY	Normal
3	FAST	Fast Play (High sp)
4	PLAY	Normal
5	FAST	Fast Play (High sp)
6	REC	Record
7	FAST	High sp
8		Leave T

Choose Test by pressing Rewind or Forward buttons

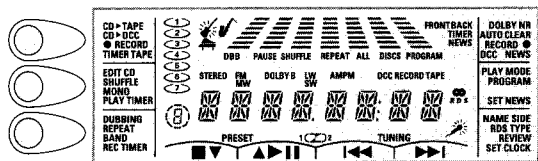
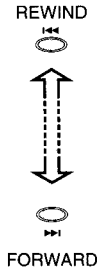


Fig.1

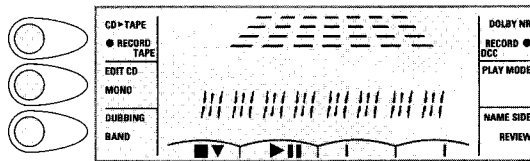
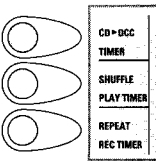


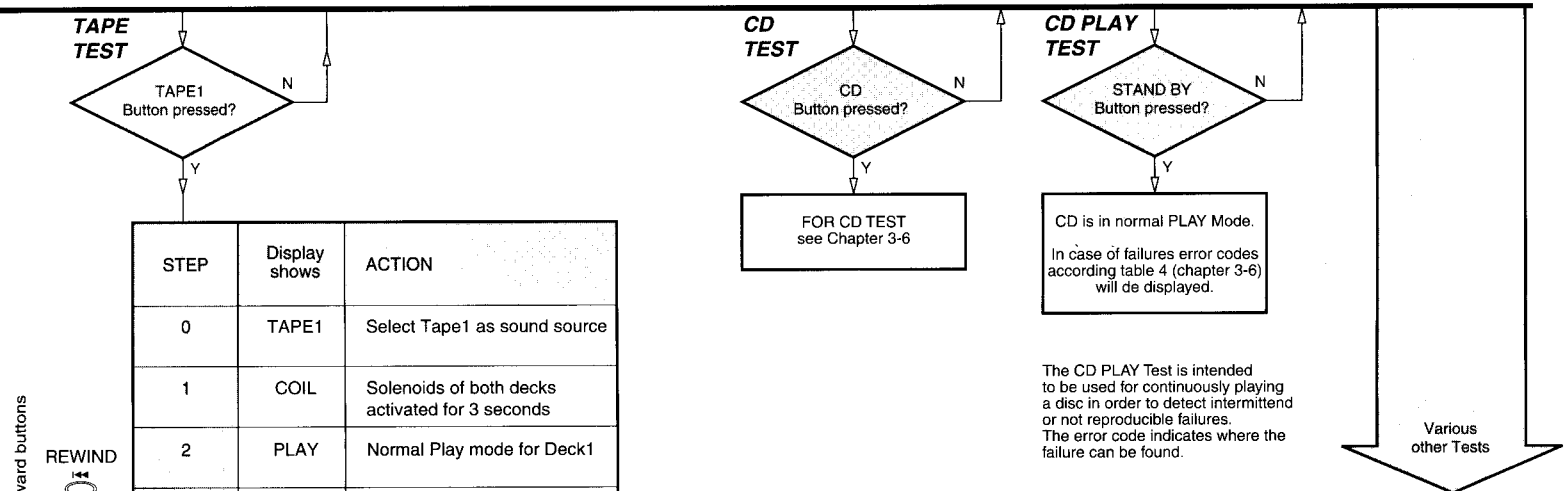
Fig.2



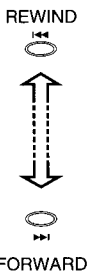
Service Testprogram
 sets with CD
 sets with CD Changer and RDS
 sets with CD Changer without RDS

software version number of μ P on Front Board
 (1.99 downwards)

software version number of μ P on Combi Board
 (1.99 downwards)



Choose Test by pressing Rewind or Forward buttons



STEP	Display shows	ACTION
0	TAPE1	Select Tape1 as sound source
1	COIL	Solenoids of both decks activated for 3 seconds
2	PLAY	Normal Play mode for Deck1
3	FAST	Fast Play mode for Deck1 (High speed)
4	PLAY	Normal Play mode for Deck2
5	FAST	Fast Play mode for Deck2 (High speed)
6	REC	Record mode for Deck2
7	FAST	High speed dubbing
8		Leave Tape Test

TEST	Activated with	ACTION
EEPROM TEST	CLASSIC	A testpattern will be sent to the EEPROM. Size of the eeprom (1K or 4K) is displayed if the pattern is read back correctly. Otherwise ERR will be displayed.
EEPROM CLEAR	JAZZ	Load default data. Display shows NEW for 1 second. Caution! All presets from the customer are lost!!
KEY TEST	OPTIMAL USER	Key numbers according table 5 are shown on the display. (see Chapter 3-6)
TEMPERATURE TEST	ROCK	Temperature of the mains transformer is displayed for 2 seconds. At 115° Celsius the μ P reduces the output power → DBB off, volume down. Values lower than 66° C are meaningless!
LEAVE SERVICE TESTPROGRAM	disconnect mains	

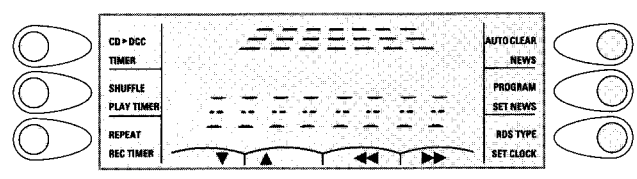
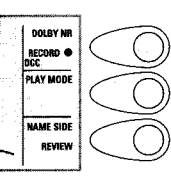


Fig.3

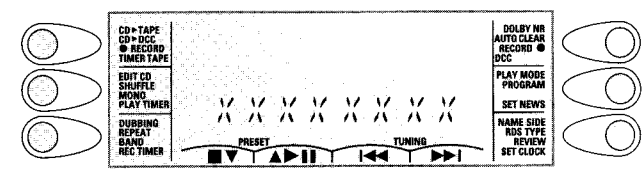


Fig.4

Error number	Error description	Error type
1002	Focus Error. Triggered when the focus could not be found within a certain time when starting up the CD or when the focus is lost for a certain time during playing the CD.	F
1007	Subcode Error. No subcode could have been read, even not after retrying 10 times to restart the PLL and jumping 10 tracks. When this happens the servo is stopped and restarted (as if the user would have pressed stop and then play immediately) to recover.	W
1008	Out of lead-in during reading TOC Triggered when during reading the TOC the lead-in (track no. 0) is left. This can be caused by a misaligned inner-switch or by a disc with a mispositioned lead-in.	W
1010	Radial error Triggered when the radial servo is not on track for a certain time during playing the CD.	F
1011	Sledge error Generated when the inner-switch did not open within a certain time when the pick up is moved from the inner position outside.	W
1012	Fatal sledge error Generated when the inner-switch did not close within a certain time when the pick up is moved inside. Inner-switch or sledge motor problems.	F
1013	Turntable motor error. Generated when the CD did not reach 75% of speed during startup within a certain time. Discmotor problem.	F
1020	PLL lock error. When the PLL did not lock after 10 retries then this warning message is generated and the servo is stopped and restarted (as if the user would have pressed stop and then play immediately) to recover.	W
1079	Tray open position not reached within a certain time.	W

Error type W = Warning, F = Fatal Error

Table 3

Key activated	Display shows	Key activated	Display shows	Key activated	Display shows
CD open/close	8	C4	19	Power / Stand by	30
Demo	9	Timer/Clock	20	CD	31
A1	10	Display	21	TUNER	32
A2	11	Analyzer	22	TAPE 1	33
A3	12	DBB	23	TAPE 2	34
B1	13	Pop / Incredible Stereo	24	MULTI MEDIA	35
B2	14	Rock	25	Vocal Cancel	36
B3	15	Classic	26	Key Control down	37
C1	16	Jazz	27	Key control up	38
C2	17	Optimal User	leave Test	any RC5 Key	RC
C3	18	Brightness	29		

Table 4

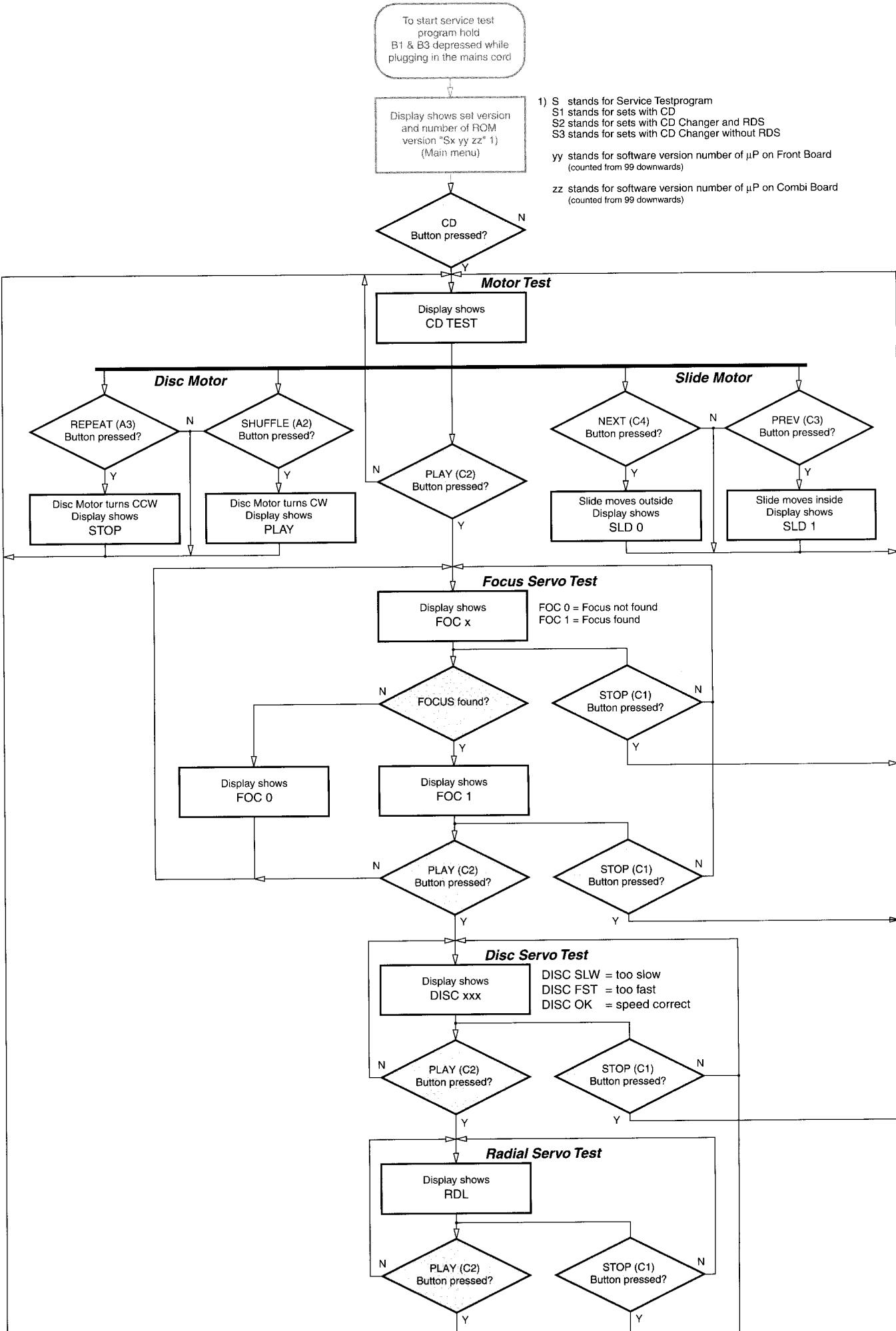
Error type
F
W
W
F
W
F
F
W
W

Display shows
30
31
32
33
34
35
36
37
38
RC

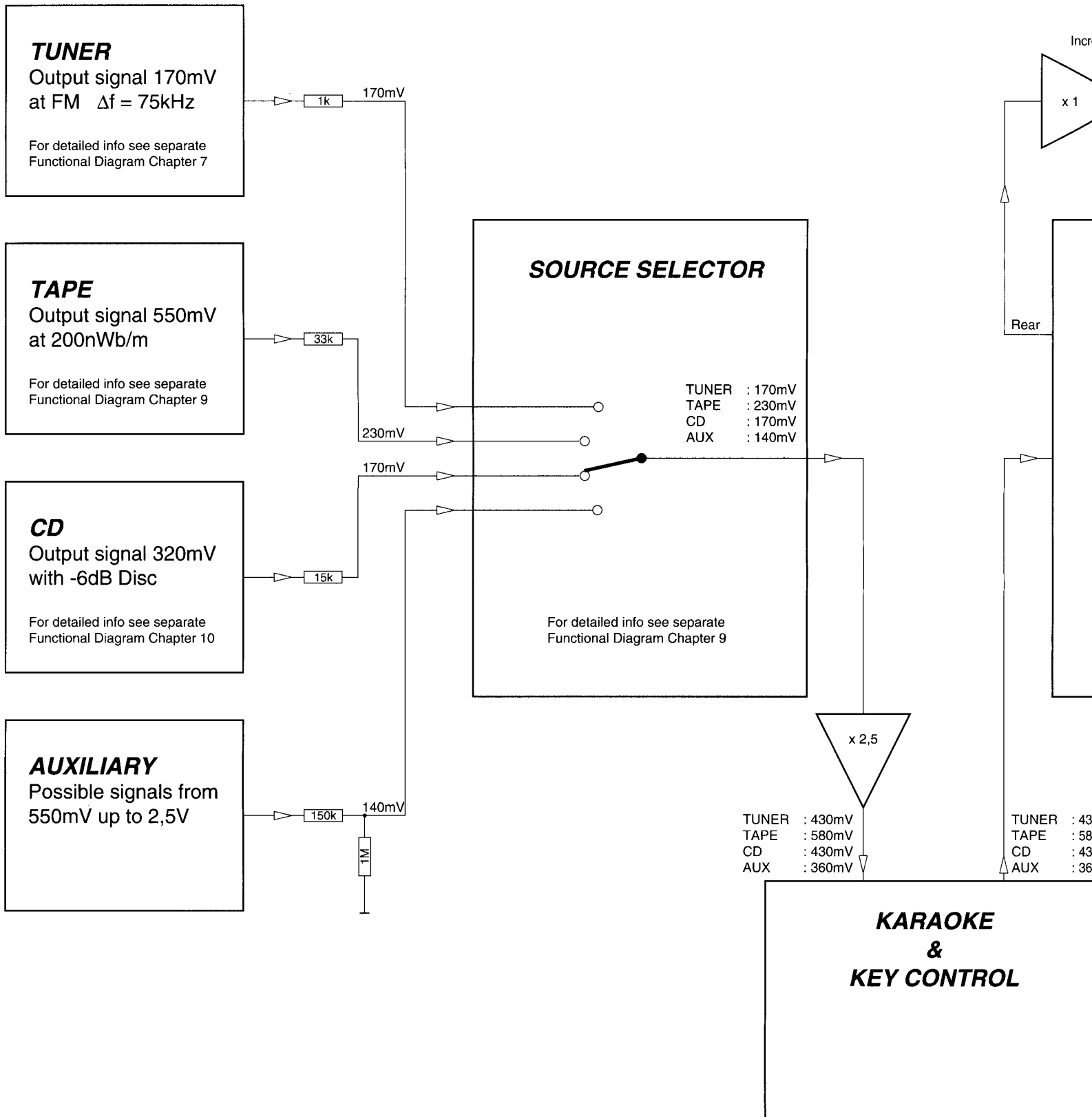
To start service test program hold B1 & B3 depressed while plugging in the mains cord

Display shows set version and number of ROM version "Sx yy zz" 1)
(Main menu)

- 1) S stands for Service Testprogram
- S1 stands for sets with CD
- S2 stands for sets with CD Changer and RDS
- S3 stands for sets with CD Changer without RDS
- yy stands for software version number of μP on Front Board (counted from 99 downwards)
- zz stands for software version number of μP on Combi Board (counted from 99 downwards)



BLOCK DIAGRAM SET



RTV servis Horvat

Kešinci, 31402 Semeljci

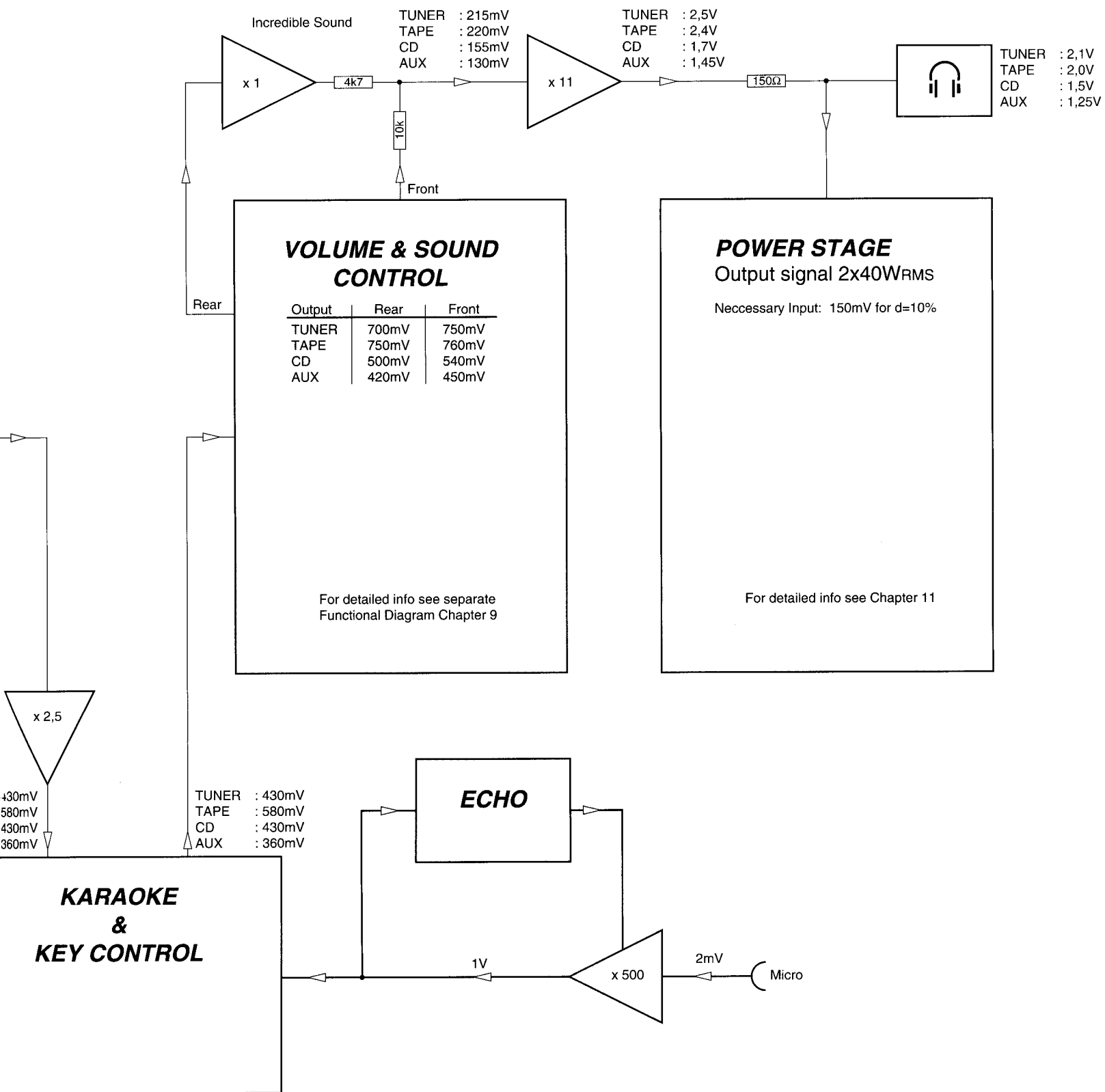
031-856-139 4-1

031-856-637

098-788-319

rtv-servis-horvat@os.tel.hr

Croatia



WIRING DIAGRAM

KARAOKE

**OPEN/CLOSE
BUTTON**
1405

COMBI

CONTROL





1403 1402 1410 1411
EC034TU82
TU84/RDS
EC057TU85
TU85/RDS

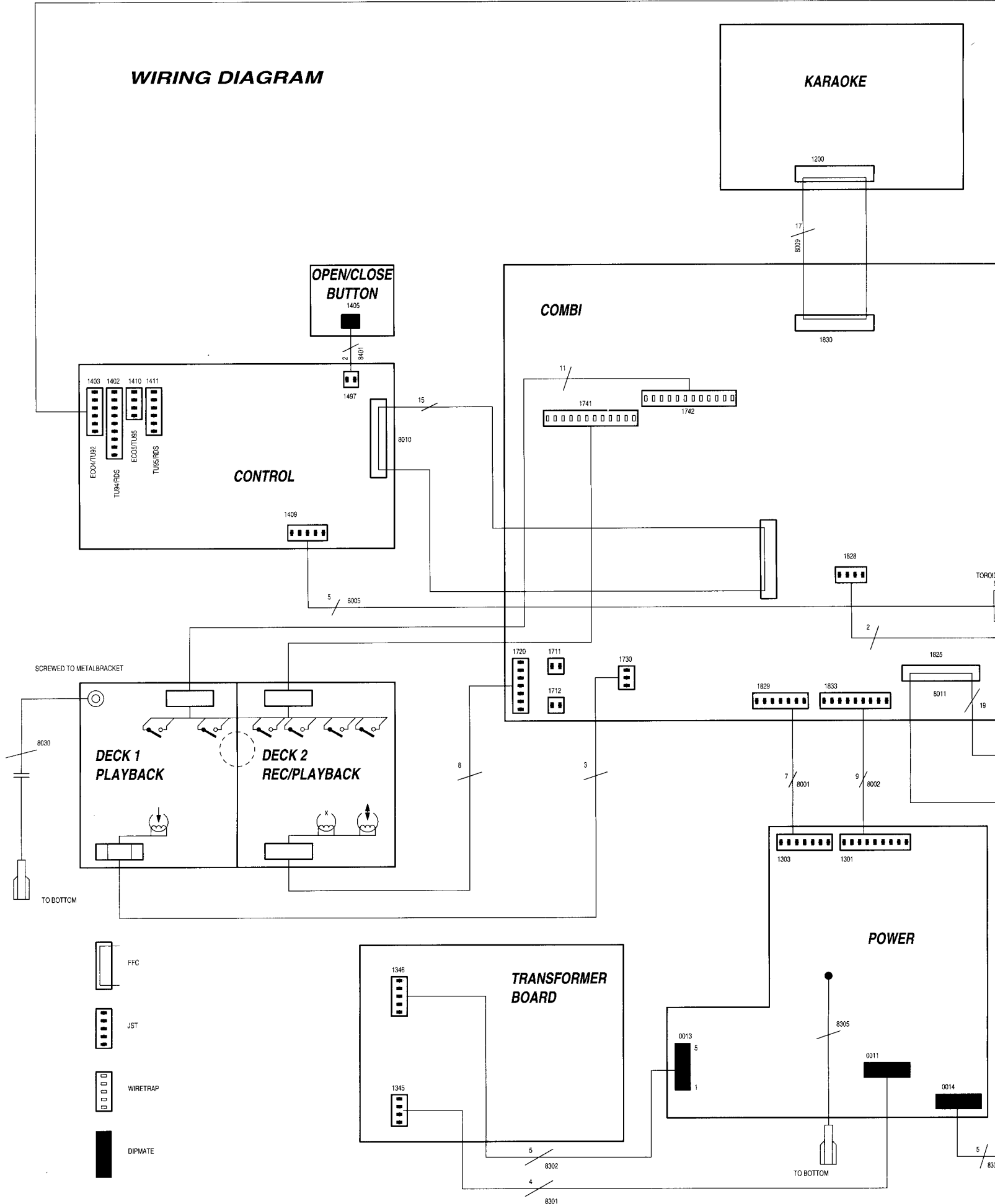
**DECK 1
PLAYBACK**

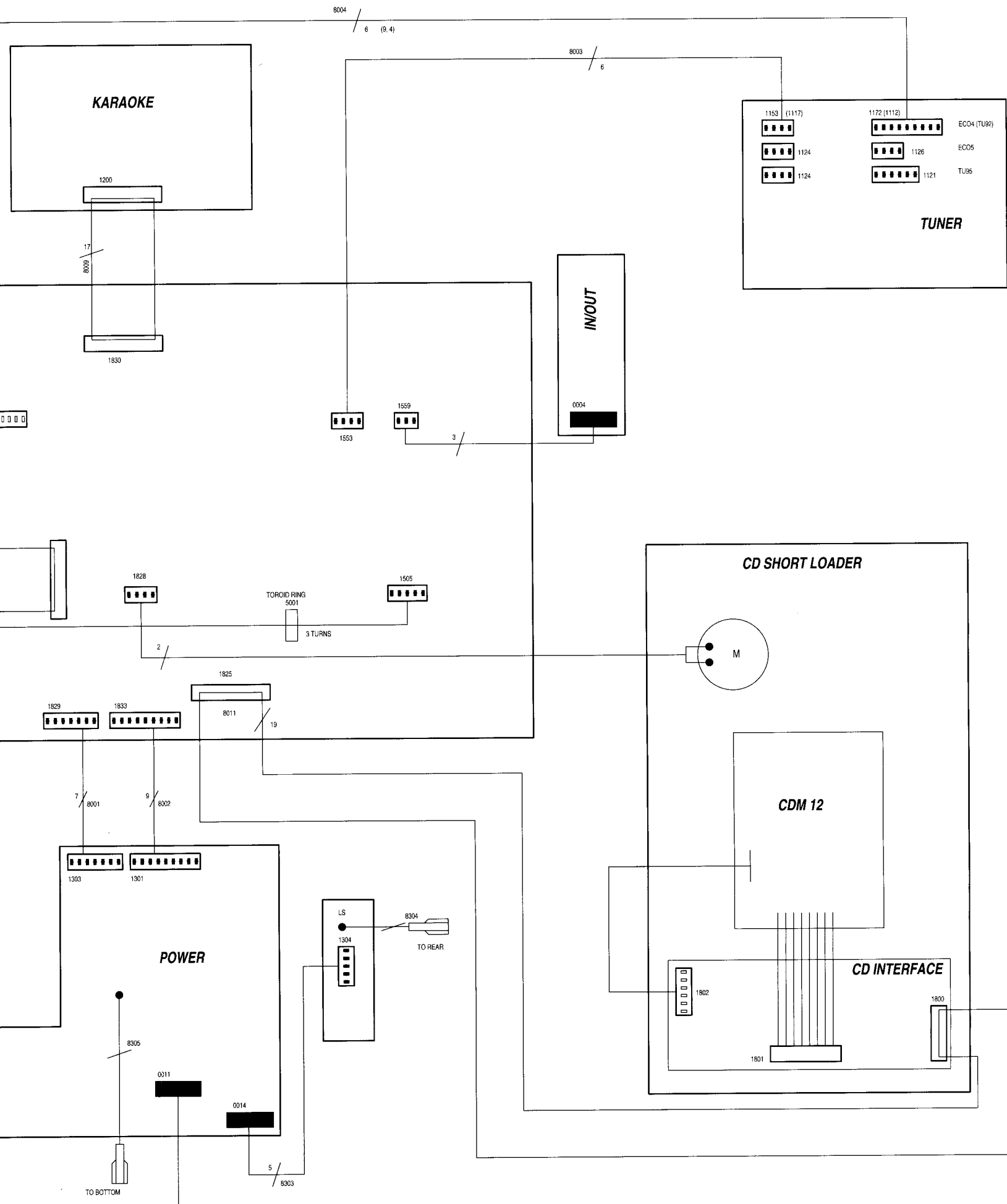
**DECK 2
REC/PLAYBACK**

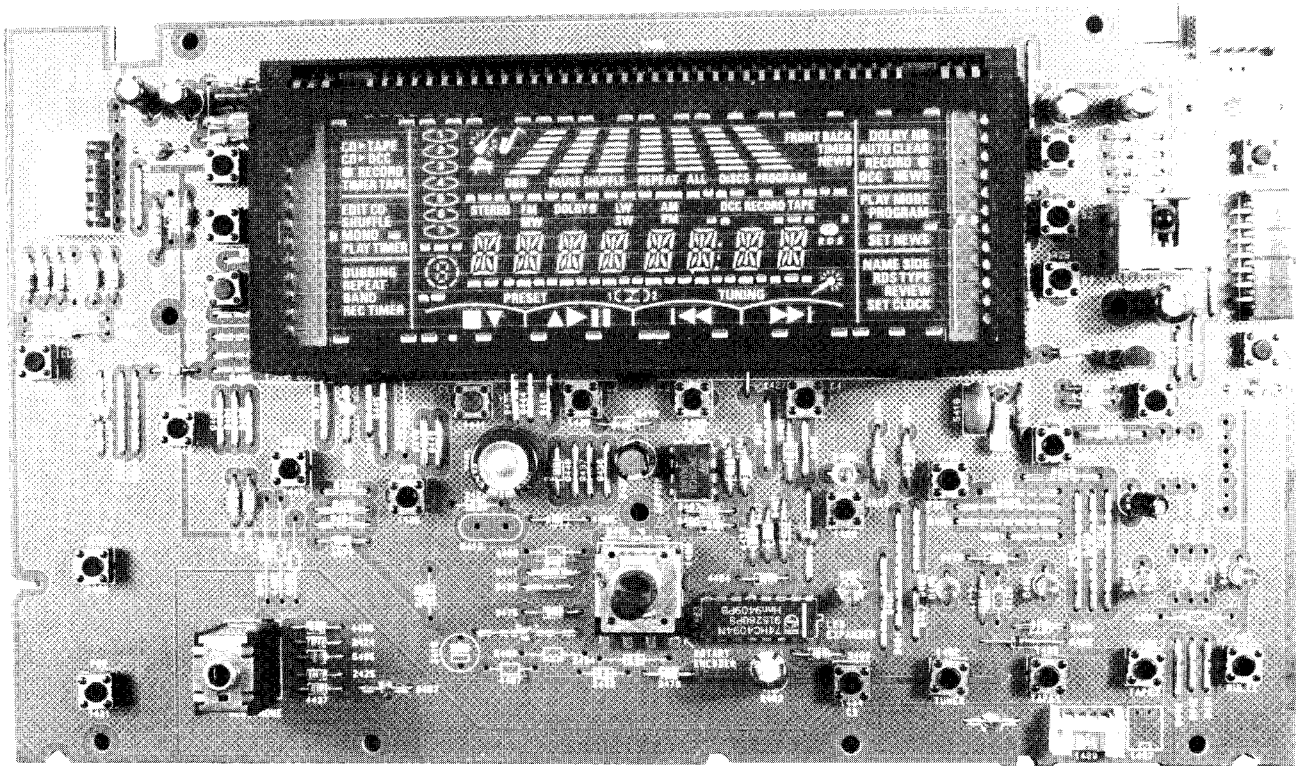
**TRANSFORMER
BOARD**

POWER

-  FFC
-  JST
-  WIRETRAP
-  DIPMATE







A

B

C

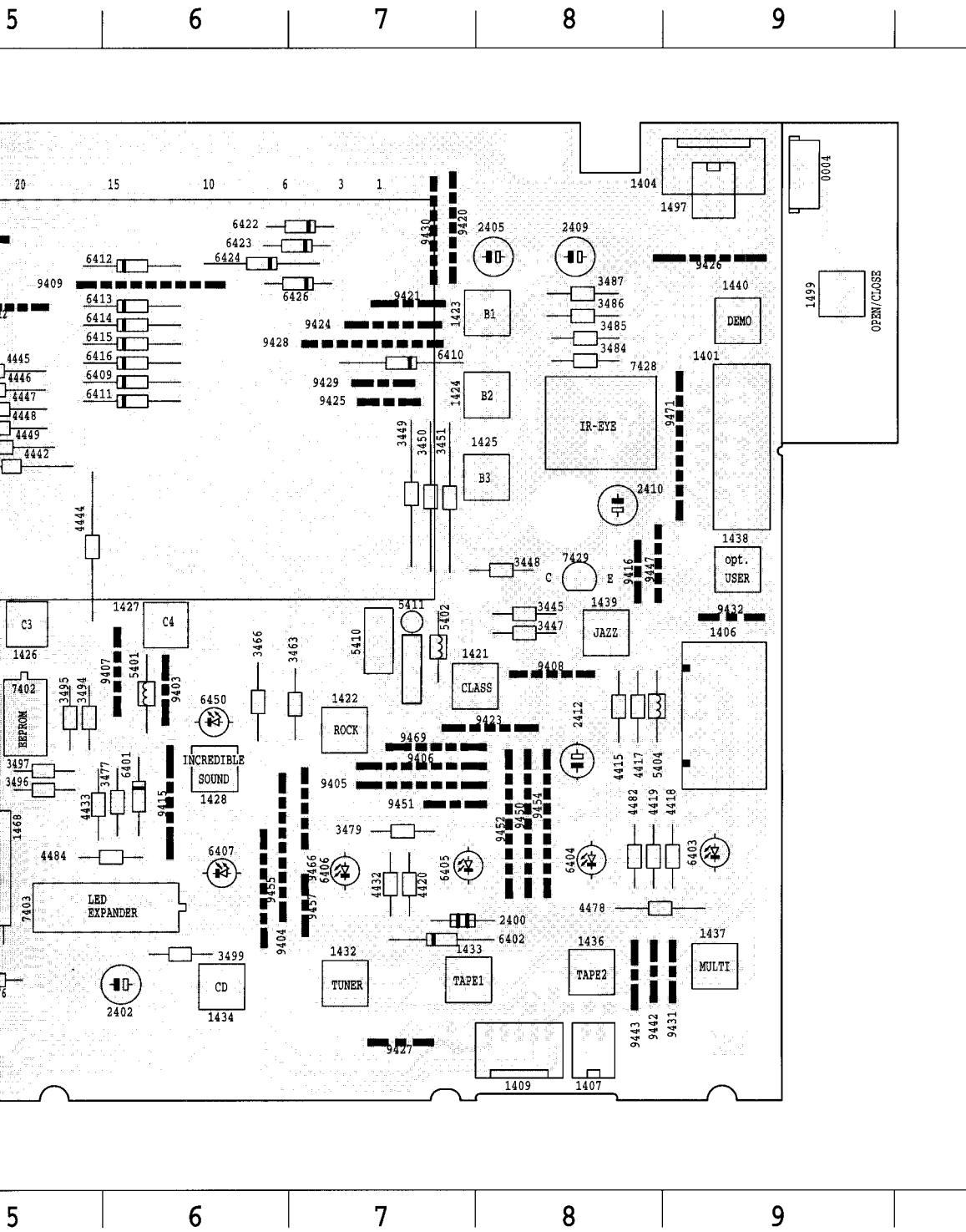
D

E

CONTROL BOARD

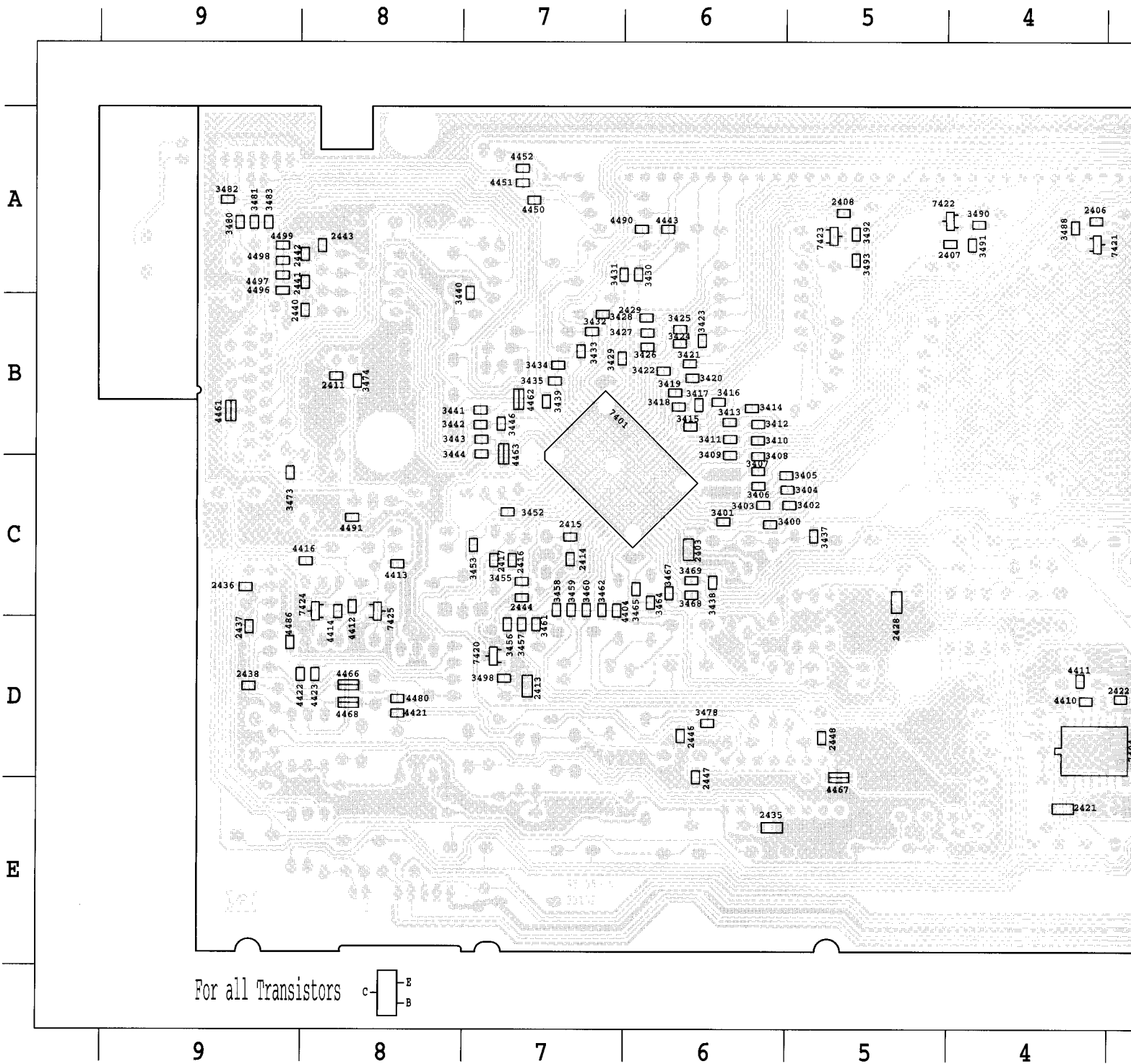
TABLE OF CONTENTS

Component layout componentside view	6-1
Circuit diagram	6-2
Component layout copperside view	6-3
CDC-keys	6-4
Partslist	6-4



0004 A 9	3448 C 8	5405 E 2	9433 B 2
1400 A 5	3449 B 7	5406 A 2	9434 C 3
1401 B 9	3450 B 7	5410 C 7	9435 C 4
1402 A 1	3451 B 7	5411 C 7	9436 D 4
1403 A 1	3463 C 7	5412 D 4	9437 D 4
1404 A 9	3466 C 6	5413 C 5	9438 A 1
1406 D 9	3472 D 4	6401 D 6	9439 D 4
1407 E 8	3475 E 4	6402 E 7	9440 D 4
1408 E 2	3476 E 5	6403 D 9	9441 C 3
1409 E 8	3477 D 6	6404 D 8	9442 E 8
1410 B 1	3479 D 7	6405 D 7	9443 E 8
1411 A 1	3484 B 8	6406 D 7	9444 C 4
1420 C 4	3485 A 8	6407 D 6	9445 C 3
1421 C 7	3486 A 8	6409 B 6	9446 C 4
1422 D 7	3487 A 8	6410 B 7	9447 C 8
1423 A 8	3489 A 4	6411 B 6	9448 C 3
1424 B 8	3494 D 5	6412 A 6	9449 C 3
1425 B 8	3495 D 5	6413 A 6	9450 D 8
1426 C 5	3496 D 5	6414 A 6	9451 D 7
1427 C 6	3497 D 5	6415 B 6	9452 D 8
1428 D 6	3499 E 6	6416 B 6	9453 C 2
1429 C 1	4403 B 2	6418 A 2	9454 D 8
1430 D 1	4407 E 4	6422 A 7	9455 D 6
1431 E 1	4409 D 4	6423 A 7	9456 C 2
1432 E 7	4415 C 8	6424 A 6	9457 E 7
1433 E 7	4417 C 8	6426 A 7	9458 D 3
1434 E 6	4418 D 9	6441 D 4	9459 A 2
1435 D 3	4419 D 8	6450 D 6	9460 C 2
1436 E 8	4420 D 7	7402 D 5	9461 C 2
1437 E 9	4424 B 1	7403 E 6	9462 C 2
1438 C 9	4425 B 1	7428 B 8	9463 C 1
1439 C 8	4426 B 1	7429 C 8	9464 D 3
1440 A 9	4427 B 1	9401 D 4	9465 D 5
1441 C 4	4428 B 1	9402 C 1	9466 D 7
1442 C 2	4430 C 1	9403 C 6	9467 E 3
1443 C 2	4431 B 1	9404 D 6	9468 C 2
1444 A 2	4432 D 7	9405 D 7	9469 D 7
1447 B 2	4433 D 5	9406 D 7	9470 C 3
1448 B 2	4436 E 2	9407 C 6	9471 B 9
1468 E 5	4437 E 2	9408 C 8	9472 E 4
1497 A 9	4442 B 5	9409 A 6	
1499 A 9	4444 C 5	9410 C 1	
2400 E 7	4445 B 5	9411 A 5	
2401 C 4	4446 B 5	9412 A 5	
2402 E 6	4447 B 5	9413 A 4	
2404 A 2	4448 B 5	9414 B 2	
2405 A 8	4449 B 5	9415 D 6	
2409 A 8	4456 A 2	9416 C 8	
2410 B 8	4458 B 1	9417 A 2	
2412 D 8	4460 D 4	9418 B 1	
2418 C 3	4470 D 2	9419 A 2	
2419 E 3	4471 D 3	9420 A 7	
2420 D 3	4472 D 2	9421 A 7	
2423 D 4	4473 B 1	9422 D 3	
2424 E 2	4478 E 8	9423 D 8	
2425 E 2	4482 D 8	9424 A 7	
2426 A 1	4484 D 6	9425 B 7	
2430 C 5	4487 D 2	9426 A 9	
2431 B 1	4488 D 2	9427 E 7	
2433 E 4	4489 C 1	9428 B 7	
2434 E 5	5401 C 6	9429 B 7	
2439 D 2	5402 C 7	9430 A 7	
3445 C 8	5403 E 4	9431 E 9	
3447 C 8	5404 C 8	9432 C 9	

COMPONENT LAYOUT COPPERSIDE VIEW





- 2403 C 6
- 2406 A 4
- 2407 A 4
- 2408 A 5
- 2411 B 8
- 2413 D 7
- 2414 C 7
- 2415 C 7
- 2416 C 7
- 2417 C 7
- A** 2421 E 4
- 2422 D 3
- 2428 C 5
- 2429 B 7
- 2435 E 6
- 2436 C 9
- 2437 D 9
- 2438 D 9
- 2440 B 8
- 2441 A 8
- 2442 A 8
- B** 2443 A 8
- 2444 C 7
- 2446 D 6
- 2447 D 6
- 2448 D 5
- 2449 B 1
- 2450 C 1
- 2451 B 1
- 2452 B 1
- C** 2453 B 1
- 2454 B 1
- 3400 C 6
- 3401 C 6
- 3402 C 5
- 3403 C 6
- 3404 C 5
- 3405 C 5
- 3406 C 6
- 3407 C 6
- 3408 C 6
- 3409 B 6
- D** 3410 B 6
- 3411 B 6
- 3412 B 6
- 3413 B 6
- 3414 B 6
- 3415 B 6
- 3416 B 6
- 3417 B 6
- 3418 B 6
- 3419 B 6
- 3420 B 6
- E** 3421 B 6
- 3422 B 6
- 3423 B 6
- 3424 B 6
- 3425 B 6
- 3426 B 6
- 3427 B 6
- 3428 B 6
- 3429 B 7
- 3430 A 6
- 3431 A 7

ELECTRICAL PARTSLIST CONTROL BOARD

ELECTRICAL PARTSLIST CONTROL BOARD

MISCELLANEOUS

1400	4822 130 91488	DISPLAY
1408	4822 267 31919	PHONE SOCKET
1420	4822 276 13114	TACT SWITCH
1421	4822 276 13114	TACT SWITCH
1422	4822 276 13114	TACT SWITCH
1423	4822 276 13114	TACT SWITCH
1424	4822 276 13114	TACT SWITCH
1425	4822 276 13114	TACT SWITCH
1426	4822 276 13114	TACT SWITCH
1427	4822 276 13114	TACT SWITCH
1428	4822 276 13114	TACT SWITCH
1429	4822 276 13114	TACT SWITCH
1430	4822 276 13114	TACT SWITCH
1431	4822 276 13114	TACT SWITCH
1432	4822 276 13114	TACT SWITCH
1433	4822 276 13114	TACT SWITCH
1434	4822 276 13114	TACT SWITCH
1435	4822 276 13114	TACT SWITCH
1436	4822 276 13114	TACT SWITCH
1437	4822 276 13114	TACT SWITCH
1438	4822 276 13114	TACT SWITCH
1439	4822 276 13114	TACT SWITCH
1440	4822 276 13114	TACT SWITCH
1441	4822 276 13114	TACT SWITCH
1442	4822 276 13114	TACT SWITCH
1443	4822 276 13114	TACT SWITCH
1446	4822 276 13114	TACT SWITCH
1447	4822 276 13114	TACT SWITCH
1448	4822 276 13114	TACT SWITCH
1468	4822 101 21261	ROTARY ENCODER
1499	4822 276 13114	TACT SWITCH

DIODES

6401	4822 130 30621	1N4148
6402	4822 130 30621	1N4148
6403	4822 130 82978	LED LTL-16KPE
6404	4822 130 82978	LED LTL-16KPE
6405	4822 130 82978	LED LTL-16KPE
6406	4822 130 82978	LED LTL-16KPE
6407	4822 130 82978	LED LTL-16KPE
6409	4822 130 30621	1N4148
6410	4822 130 30621	1N4148
6411	4822 130 30621	1N4148
6412	4822 130 30621	1N4148
6413	4822 130 30621	1N4148
6414	4822 130 30621	1N4148
6415	4822 130 30621	1N4148
6416	4822 130 30621	1N4148
6418	4822 130 30621	1N4148
6422	4822 130 30621	1N4148
6423	4822 130 30621	1N4148
6424	4822 130 30621	1N4148
6426	4822 130 30621	1N4148
6441	4822 130 30621	1N4148
6450	4822 130 83363	LED LTL-16KGE

TRANSISTORS

7420	5322 130 42755	BC847C
7421	5322 130 42755	BC847C
7422	5322 130 42755	BC847C
7423	5322 130 42755	BC847C
7429	5322 130 60068	BC558C

INTEGRATED CIRCUITS

7401	4822 209 90995	TMP87CP71F-65SV83021
7402	4822 209 32709	ST24C04CB1 not for /22
7402	4822 209 31508	ST24C01CB1 only for /22
7403	5322 209 11532	PC74HC4094P
7404	4822 209 31981	SAA6579T/V1
7428	4822 214 52009	GP1U58XP

COILS

5401	4822 157 62552	2,2μH
5402	4822 157 62552	2,2μH
5403	4822 157 62552	2,2μH
5405	4822 157 62552	2,2μH
5406	4822 157 52333	100μH 10%
5410	5322 242 73697	CER.RES. 8MHZ
5411	4822 242 70938	XTAL 32,768kHz
5412	4822 242 72195	XTAL 4,332MHZ
5413	4822 157 62552	2,2μH

RESISTORS

3449	4822 050 11002	1k	5%	0,2W
3450	4822 050 11002	1k	5%	0,2W
3451	4822 050 11002	1k	5%	0,2W
3463	4822 050 11002	1k	5%	0,2W
3472	4822 116 52228	680R	5%	0,5W
3475	4822 116 83864	10k	5%	0,5W
3476	4822 116 83864	10k	5%	0,5W
3477	4822 116 83864	10k	5%	0,5W
3479	4822 116 83864	10k	5%	0,5W
3484	4822 050 11002	1k	5%	0,2W
3485	4822 050 11002	1k	5%	0,2W
3486	4822 050 11002	1k	5%	0,2W
3487	4822 050 11002	1k	5%	0,2W
3489	4822 116 52234	100k	5%	0,5W
3494	4822 116 52284	47k	5%	0,5W
3495	4822 116 52284	47k	5%	0,5W
3496	4822 050 11002	1k	5%	0,2W
3497	4822 050 11002	1k	5%	0,2W
3499	4822 116 52235	1M	5%	0,5W
4403	4822 116 52289	5k6	5%	0,16W
4407	4822 116 83864	10k	5%	0,5W
4409	4822 116 83864	10k	5%	0,5W
4424	4822 050 11002	1k	5%	0,2W
4425	4822 050 11002	1k	5%	0,2W
4426	4822 050 11002	1k	5%	0,2W
4427	4822 050 11002	1k	5%	0,2W
4428	4822 050 11002	1k	5%	0,2W
4430	4822 050 11002	1k	5%	0,2W
4431	4822 050 11002	1k	5%	0,2W
4432	4822 116 52219	330R	5%	0,5W
4433	4822 116 52219	330R	5%	0,5W
4436	4822 116 83864	10k	5%	0,5W
4437	4822 116 83864	10k	5%	0,5W
4442	4822 116 52219	330R	5%	0,5W
4444	4822 116 52219	330R	5%	0,5W

RESISTORS

4445	4822 116
4446	4822 116
4447	4822 116
4448	4822 116
4449	4822 116
4456	4822 116
4458	4822 116
4460	4822 050
4470	4822 116
4471	4822 116
4472	4822 116
4473	4822 116
4473	4822 116
4489	4822 116

CHIP RESISTORS

3400	4822 051
3401	4822 051
3402	4822 051
3403	4822 051
3404	4822 051
3405	4822 051
3406	4822 051
3407	4822 051
3408	4822 051
3409	4822 051
3410	4822 051
3411	4822 051
3412	4822 051
3413	4822 051
3414	4822 051
3415	4822 051
3416	4822 051
3417	4822 051
3418	4822 051
3419	4822 051
3420	4822 051
3421	4822 051
3422	4822 051
3423	4822 051
3424	4822 051
3425	4822 051
3426	4822 051
3427	4822 051
3428	4822 051
3429	4822 051
3430	4822 051
3431	4822 051
3432	4822 051
3433	4822 051
3434	4822 051
3435	4822 051
3437	4822 051
3438	4822 051
3439	4822 051
3440	4822 051
3441	4822 051
3442	4822 051
3443	4822 051
3444	4822 051
3446	4822 051

ELECTRICAL PARTSLIST CONTROL BOARD**RESISTORS**

4445	4822 116 52219	330R	5%	0,5W
4446	4822 116 52219	330R	5%	0,5W
4447	4822 116 52219	330R	5%	0,5W
4448	4822 116 52219	330R	5%	0,5W
4449	4822 116 52219	330R	5%	0,5W
4456	4822 116 52219	330R	5%	0,5W
4458	4822 116 83864	10k	5%	0,5W
4460	4822 050 11002	1k	5%	0,2W
4470	4822 116 52285	470k	5%	0,16W
4471	4822 116 52285	470k	5%	0,16W
4472	4822 116 52285	470k	5%	0,16W
4473	4822 116 52263	2k7	5%	0,5W for ECO4,Tuner94
4473	4822 116 52296	6k8	5%	0,5W for ECO5,Tuner95
4489	4822 116 52284	47k	5%	0,5W

CHIP RESISTORS

3400	4822 051 10102	1k	2%	0,25W
3401	4822 051 20101	100R	5%	0,1W
3402	4822 051 20101	100R	5%	0,1W
3403	4822 051 20101	100R	5%	0,1W
3404	4822 051 20101	100R	5%	0,1W
3405	4822 051 20101	100R	5%	0,1W
3406	4822 051 20101	100R	5%	0,1W
3407	4822 051 20101	100R	5%	0,1W
3408	4822 051 20101	100R	5%	0,1W
3409	4822 051 20101	100R	5%	0,1W
3410	4822 051 10102	1k	2%	0,25W
3411	4822 051 20689	68R	5%	0,1W
3412	4822 051 20689	68R	5%	0,1W
3413	4822 051 20689	68R	5%	0,1W
3414	4822 051 20689	68R	5%	0,1W
3415	4822 051 10102	1k	2%	0,25W
3416	4822 051 20391	390R	5%	0,1W
3417	4822 051 20331	330R	5%	0,1W
3418	4822 051 20221	220R	5%	0,1W
3419	4822 051 20331	330R	5%	0,1W
3420	4822 051 20271	270R	5%	0,1W
3421	4822 051 20271	270R	5%	0,1W
3422	4822 051 20331	330R	5%	0,1W
3423	4822 051 20271	270R	5%	0,1W
3424	4822 051 20221	220R	5%	0,1W
3425	4822 051 20271	270R	5%	0,1W
3426	4822 051 20221	220R	5%	0,1W
3427	4822 051 20391	390R	5%	0,1W
3428	4822 051 20151	150R	5%	0,1W
3429	4822 051 20221	220R	5%	0,1W
3430	4822 051 20391	390R	5%	0,1W
3431	4822 051 20331	330R	5%	0,1W
3432	4822 051 20331	330R	5%	0,1W
3433	4822 051 20331	330R	5%	0,1W
3434	4822 051 20331	330R	5%	0,1W
3435	4822 051 20331	330R	5%	0,1W
3437	4822 051 20103	10k	5%	0,1W
3438	4822 051 20103	10k	5%	0,1W
3439	4822 051 10102	1k	2%	0,25W
3440	4822 051 20105	1M	5%	0,1W
3441	4822 051 10102	1k	2%	0,25W
3442	4822 051 10102	1k	2%	0,25W
3443	4822 051 10102	1k	2%	0,25W
3444	4822 051 10102	1k	2%	0,25W
3446	4822 051 10102	1k	2%	0,25W

CHIP RESISTORS

3452	4822 051 10102	1k	2%	0,25W
3453	4822 051 10102	1k	2%	0,25W
3455	4822 051 10102	1k	2%	0,25W
3456	4822 051 20103	10k	5%	0,1W
3457	4822 051 20103	10k	5%	0,1W
3458	4822 051 20222	2k2	5%	0,1W
3462	4822 051 10102	1k	2%	0,25W
3464	4822 051 10102	1k	2%	0,25W
3465	4822 051 10102	1k	2%	0,25W
3467	4822 051 20103	10k	5%	0,1W
3468	4822 051 20103	10k	5%	0,1W
3469	4822 051 20332	3k3	5%	0,1W
3473	4822 051 20479	47R	5%	0,1W
3474	4822 051 10102	1k	2%	0,25W
3478	4822 051 20103	10k	5%	0,1W
3480	4822 051 20103	10k	5%	0,1W
3481	4822 051 10102	1k	2%	0,25W
3482	4822 051 10102	1k	2%	0,25W
3483	4822 051 20684	680k	5%	0,1W
3488	4822 051 20229	22R	5%	0,1W
3490	4822 051 20229	22R	5%	0,1W
3491	4822 051 20104	100k	5%	0,1W
3492	4822 051 20229	22R	5%	0,1W
3493	4822 051 20104	100k	5%	0,1W
3498	4822 051 20104	100k	5%	0,1W
4404	4822 051 20223	22k	5%	0,1W
4410	4822 051 20224	220k	5%	0,1W
4411	4822 051 20222	2k2	5%	0,1W
4443	4822 051 20331	330R	5%	0,1W
4450	4822 051 20331	330R	5%	0,1W
4451	4822 051 20331	330R	5%	0,1W
4452	4822 051 20331	330R	5%	0,1W
4461	4822 051 10008	CHIP JUMPER 1206		
4462	4822 051 10008	CHIP JUMPER 1206		
4463	4822 051 10008	CHIP JUMPER 1206		
4467	4822 051 10008	CHIP JUMPER 1206		
4491	4822 051 20223	22k	5%	0,1W
4496	4822 051 20473	47k	5%	0,1W
4497	4822 051 20473	47k	5%	0,1W
4498	4822 051 20473	47k	5%	0,1W
4499	4822 051 20473	47k	5%	0,1W

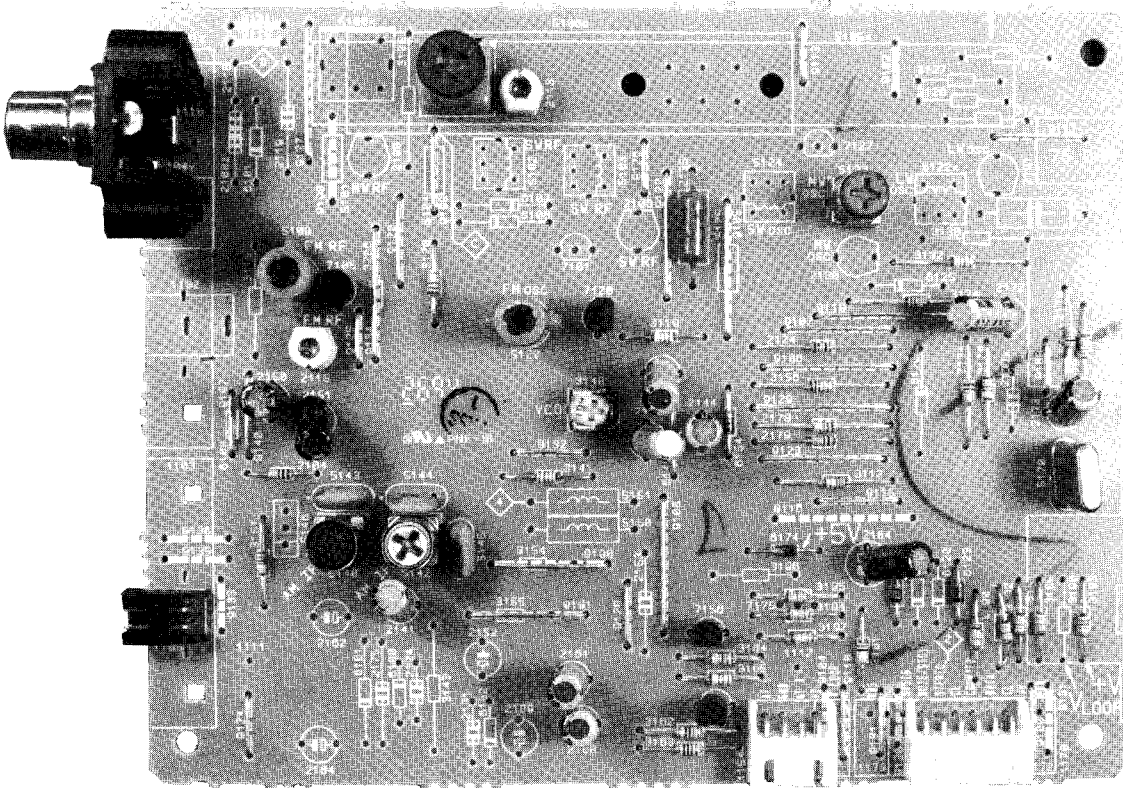
CAPACITORS

2401	4822 124 80818	22mF	20%	5,5V
2402	4822 124 41584	100µF	20%	10V
2404	4822 124 41579	10µF	20%	50V
2405	4822 124 41579	10µF	20%	50V
2409	4822 124 41579	10µF	20%	50V
2410	4822 124 41584	100µF	20%	10V
2412	4822 124 22403	10µF	20%	16V
2418	4822 126 12787	330pF	10%	50V
2419	4822 124 41576	2,2µF	20%	50V
2420	4822 122 10459	560pF	10%	50V
2423	4822 122 33848	47pF	5%	50V
2424	4822 121 51387	10nF	20%	16V
2425	4822 121 51387	10nF	20%	16V
2426	4822 124 40433	47µF	20%	25V
2430	4822 124 42234	100µF	20%	6,3V
2431	4822 122 33195	100pF	10%	50V
2403	4822 122 33496	100nF	10%	63V
2406	5322 122 32448	10pF	5%	50V

ELECTRICAL PARTSLIST CONTROL BOARD

CHIP CAPACITORS

2407	5322 122 32448	10pF	5%	50V
2408	5322 122 32448	10pF	5%	50V
2411	4822 122 33175	2,2nF	20%	50V
2413	4822 122 33496	100nF	10%	63V
2414	5322 122 32658	22pF	5%	50V
2415	5322 122 32658	22pF	5%	50V
2416	5322 122 32658	22pF	5%	50V
2417	5322 122 32269	6,8pF	5%	50V
2421	4822 122 33496	100nF	10%	63V
2422	5322 122 32452	47pF	5%	50V
2428	4822 122 33496	100nF	10%	63V
2429	4822 122 33177	10nF	20%	50V
2435	4822 126 11692	1µF	20%	16V
2440	5322 122 32452	47pF	5%	50V
2441	5322 122 32452	47pF	5%	50V
2442	5322 122 32452	47pF	5%	50V
2443	5322 122 32452	47pF	5%	50V
2444	4822 122 33342	33nF	10%	63V
2446	5322 122 32531	100pF	5%	50V
2447	5322 122 32531	100pF	5%	50V
2448	5322 122 32531	100pF	5%	50V
2449	5322 122 34099	470pF	10%	63V
2450	5322 122 34099	470pF	10%	63V
2451	5322 122 34099	470pF	10%	63V
2452	5322 122 34099	470pF	10%	63V
2453	5322 122 34099	470pF	10%	63V
2454	5322 122 34099	470pF	10%	63V

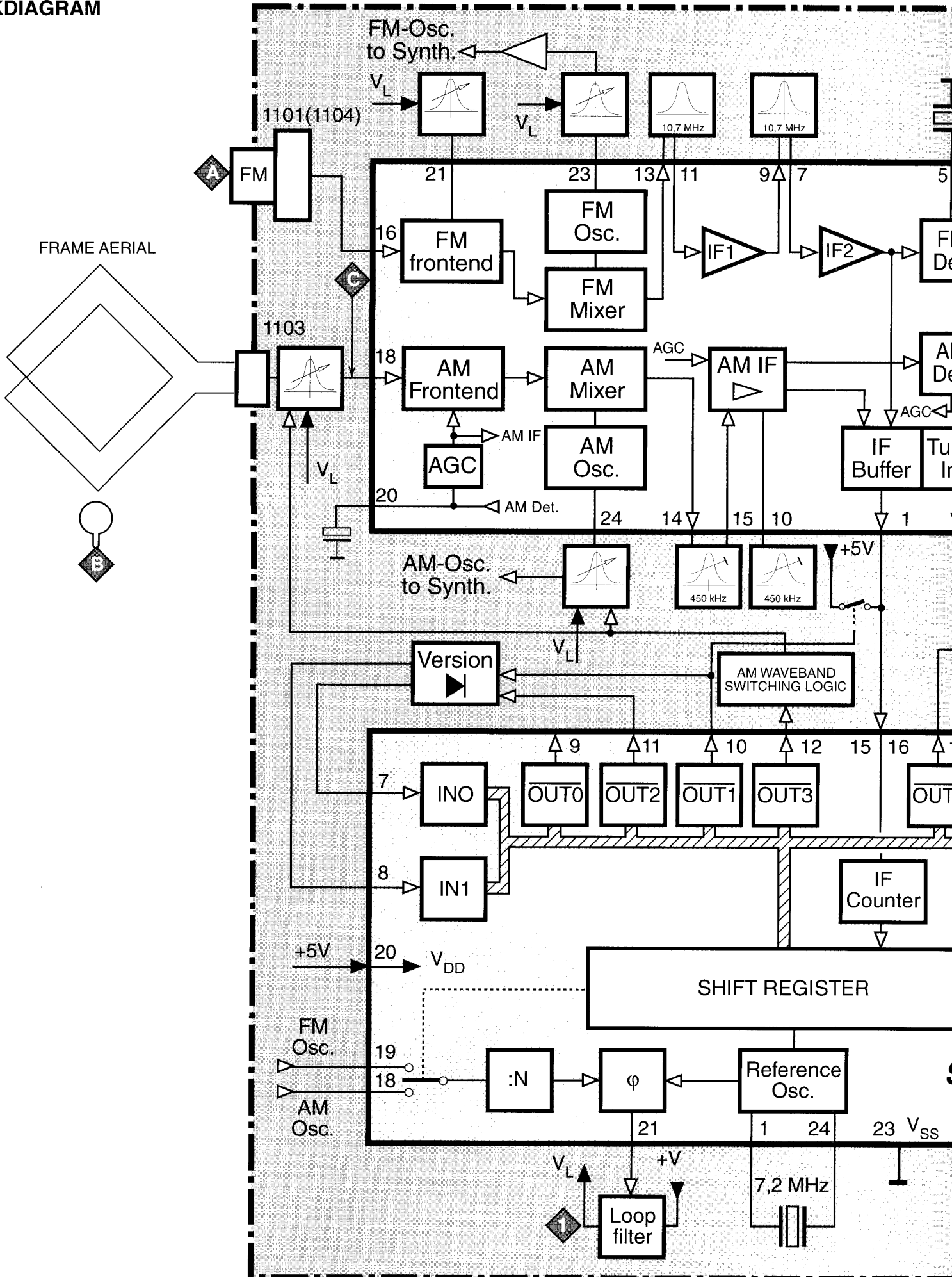


TUNER BOARD ECO4VA

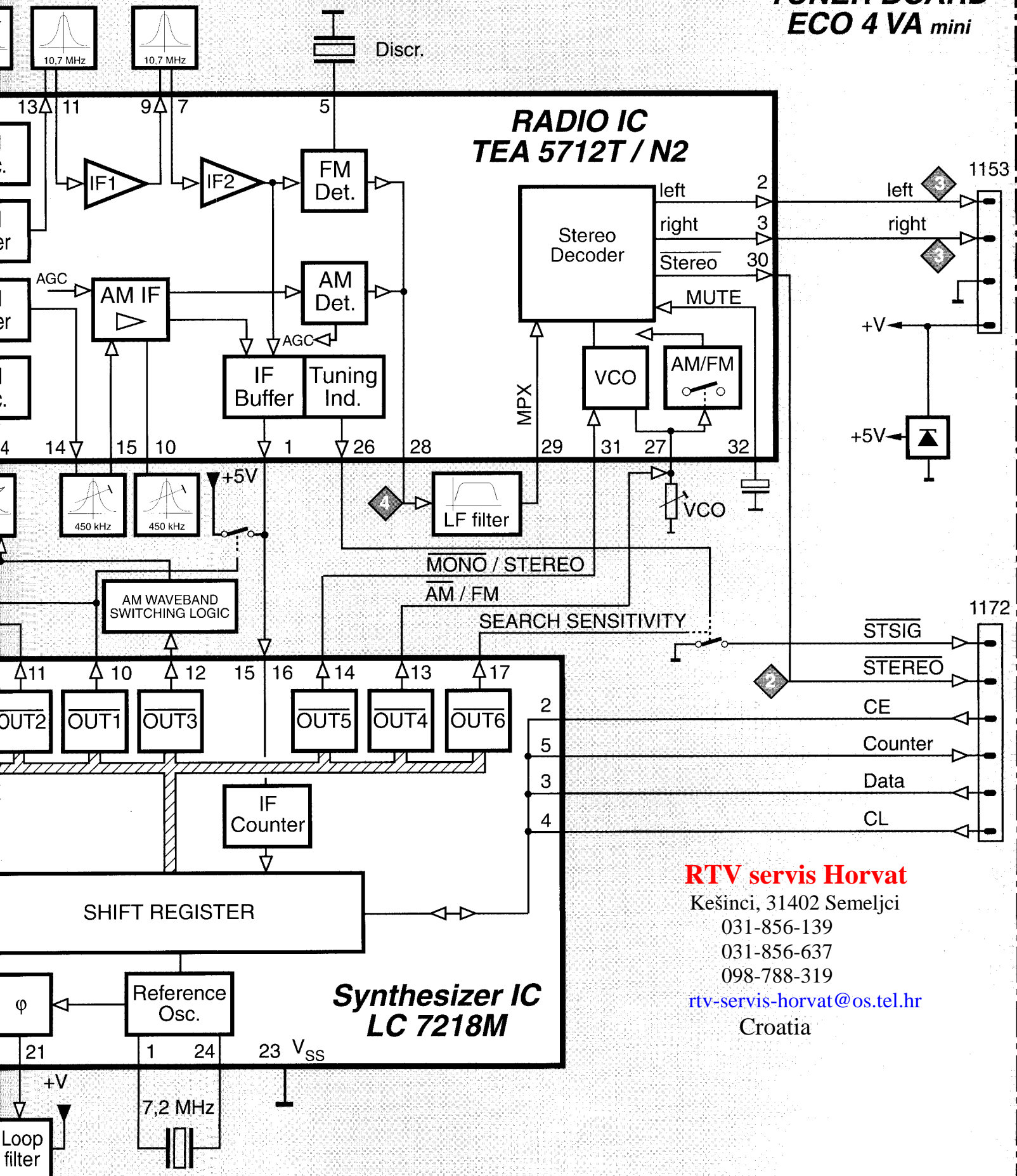
TABLE OF CONTENTS

Blockdiagram	7A-1
Adjustmant table	7A-2
Component layout	7A-2
Circuit diagram	7A-3
Partslist	7A-4

BLOCKDIAGRAM



TUNER BOARD ECO 4 VA mini



RTV servis Horvat

Kešinci, 31402 Semeljci

031-856-139

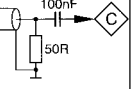
031-856-637

098-788-319

rtv-servis-horvat@os.tel.hr

Croatia

TUNER ADJUSTMENT TABLE (ECO4VA FM/MW- and FM/MW/LW - versions with AM-frame aerial)

Waverange	Input frequency	Input	Tuned to	Adjust	Output	Scope/Voltmeter
<i>VARICAP ALIGNMENT</i>						
FM			108MHz	5120	◇ 1	8V ±0.2V
87.5 - 108MHz			87.5MHz	check		4.1V ±0.5V
FM East Europe			108MHz	5120		8V ±0.2V
65.81 - 108MHz			65.81MHz	check		0.8V ±0.4V
MW			1710kHz	5123		9V ±0.1V
2-band version			530kHz	check		1V ±0.4V
530 - 1710kHz						
LW			279kHz	5122		8V ±0.2V
153 - 279kHz			153kHz	check		1V ±0.4V
MW			1611kHz	5123		8V ±0.1V
3-band version			522kHz	check		1V ±0.4V
522 - 1611kHz						
<i>FM RF</i>						
FM	108MHz	◇ A mod=1kHz Δf=22.5kHz	108MHz	2115	◇ 3	MAX
87.5 - 108MHz	87.5MHz		87.5MHz	5109		
FM East Europe	108MHz		108MHz	2115		
65.81 - 108MHz	65.81MHz		65.81MHz	5109		
<i>VCO</i>						
FM	98MHz, 1mV continuous wave	◇ A	98MHz	3148	◇ 2	152kHz ±1kHz
<i>AM IF</i>						
MW	540kHz Δf=10kHz as low as possible		540kHz	5142 5140	◇ 4	symmetrical and max. height
<i>AM RF ¹⁾</i>						
LW	198kHz	◇ B mod=1kHz 30% AM	198kHz	5108	◇ 4	MAX
MW	1494kHz		1494kHz	2113		MAX
3-band version	549kHz		549kHz	5107		
522 - 1611kHz			1500kHz	2113		
MW	1500kHz		550kHz	5107		
2-band version	530 - 1710kHz					

ECO4VA mini a: 290595

Use service test program. By selecting the TUNER TEST test frequencies will be stored as preset frequencies automatically.

¹⁾ For AM RF adjustments the original frame antenna 4822 158 60622 has to be used !

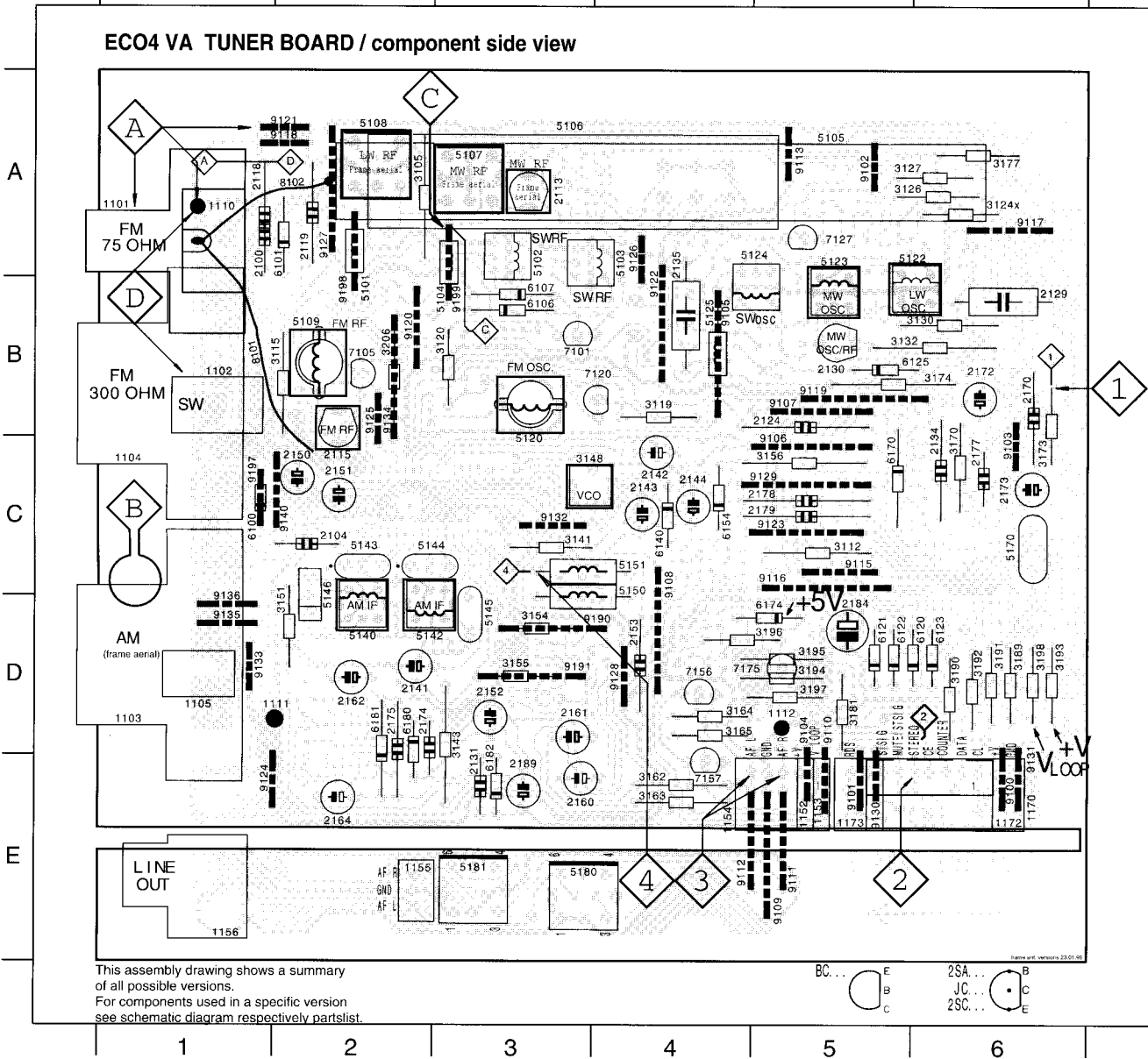
↑ Repeat

1101 A 1	1173 E 5	2142 C 4	2175 D 2	3127 A 6	3173 B 6	5101 A 2	5142 D 2	6121 D 5	7156 D 4	9110 E 5	9126 A 4	9198 A 2
1102 B 1	2100 A 1	2143 C 4	2177 C 6	3130 B 6	3174 B 5	5102 A 3	5143 C 2	6122 D 5	7157 E 4	9111 E 5	9127 A 4	9199 A 3
1103 D 1	2104 C 2	2144 C 4	2178 C 5	3132 B 6	3177 A 6	5103 A 3	5144 C 2	6123 D 6	7175 D 5	9112 E 4	9128 D 4	
1104 B 1	2106 B 4	2150 C 2	2179 C 5	3141 C 3	3181 D 5	5104 A 3	5145 D 3	6125 B 5	8101 B 1	9113 A 5	9129 C 5	
1105 D 1	2113 A 3	2151 C 2	2184 D 5	3143 D 3	3189 D 6	5105 A 4	5146 D 2	6140 C 4	8102 A 1	9115 C 5	9130 E 5	
1110 A 1	2115 B 2	2152 D 3	2189 E 3	3148 C 3	3190 D 6	5106 A 4	5150 D 3	6154 C 4	9100 E 6	9116 C 5	9131 E 6	
1111 D 2	2118 A 1	2153 D 4	2190 A 2	3151 D 2	3191 D 6	5107 A 3	5151 C 3	6170 C 5	9101 E 5	9117 A 6	9132 C 3	
1112 D 5	2119 A 2	2160 E 3	2191 A 6	3154 D 3	3192 D 6	5108 A 2	5170 C 6	6174 D 5	9102 A 5	9118 A 2	9133 D 1	
1152 E 5	2124 B 5	2161 D 3	3105 A 2	3155 D 3	3193 D 6	5109 B 2	5180 E 3	6180 D 2	9103 C 6	9119 B 5	9134 B 2	
1153 E 5	2129 B 6	2162 D 2	3112 C 5	3156 C 5	3194 D 5	5120 B 3	5181 E 3	6181 D 2	9104 E 5	9120 B 2	9135 D 1	
1154 E 4	2130 B 5	2164 F 2	3115 B 2	3162 F 4	3195 D 5	5122 B 6	6100 C 1	6182 C 3	9105 B 4	9121 A 2	9136 D 1	
1155 E 2	2131 E 3	2170 B 6	3119 B 4	3163 E 4	3196 D 4	5123 B 5	6101 A 2	7101 B 3	9106 C 5	9122 B 4	9140 C 2	
1156 E 1	2134 C 6	2172 B 6	3120 B 3	3164 D 4	3197 D 5	5124 B 5	6106 B 3	7105 B 2	9107 B 5	9123 C 5	9190 D 3	
1170 E 6	2135 B 4	2173 C 6	3124 A 6	3165 D 4	3198 D 6	5125 B 4	6107 B 3	7120 B 4	9108 D 4	9124 E 1	9191 D 3	
1172 E 6	2141 D 2	2174 D 2	3126 A 6	3170 C 6	3206 B 2	5140 D 2	6120 D 6	7127 A 5	9109 E 5	9125 B 2	9197 C 1	

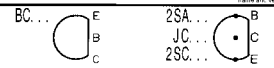
o for AM-version only
 x for LW-version only
 y for USA version only
 z not for all versions

2101 A 2	2102 A 4	2103 C 2	2105 B 3	2107 B 2	2108 A 3	2109 B 4	2110 A 4	2111 B 3	2112 B 4	2113 B 2	2114 A 3	2116 B 2	2117 A 4	2120 B 3	2121 B 2
----------	----------	----------	----------	----------	----------	----------	----------	----------	----------	----------	----------	----------	----------	----------	----------

ECO4 VA TUNER BOARD / component side view



This assembly drawing shows a summary of all possible versions. For components used in a specific version see schematic diagram respectively partslist.

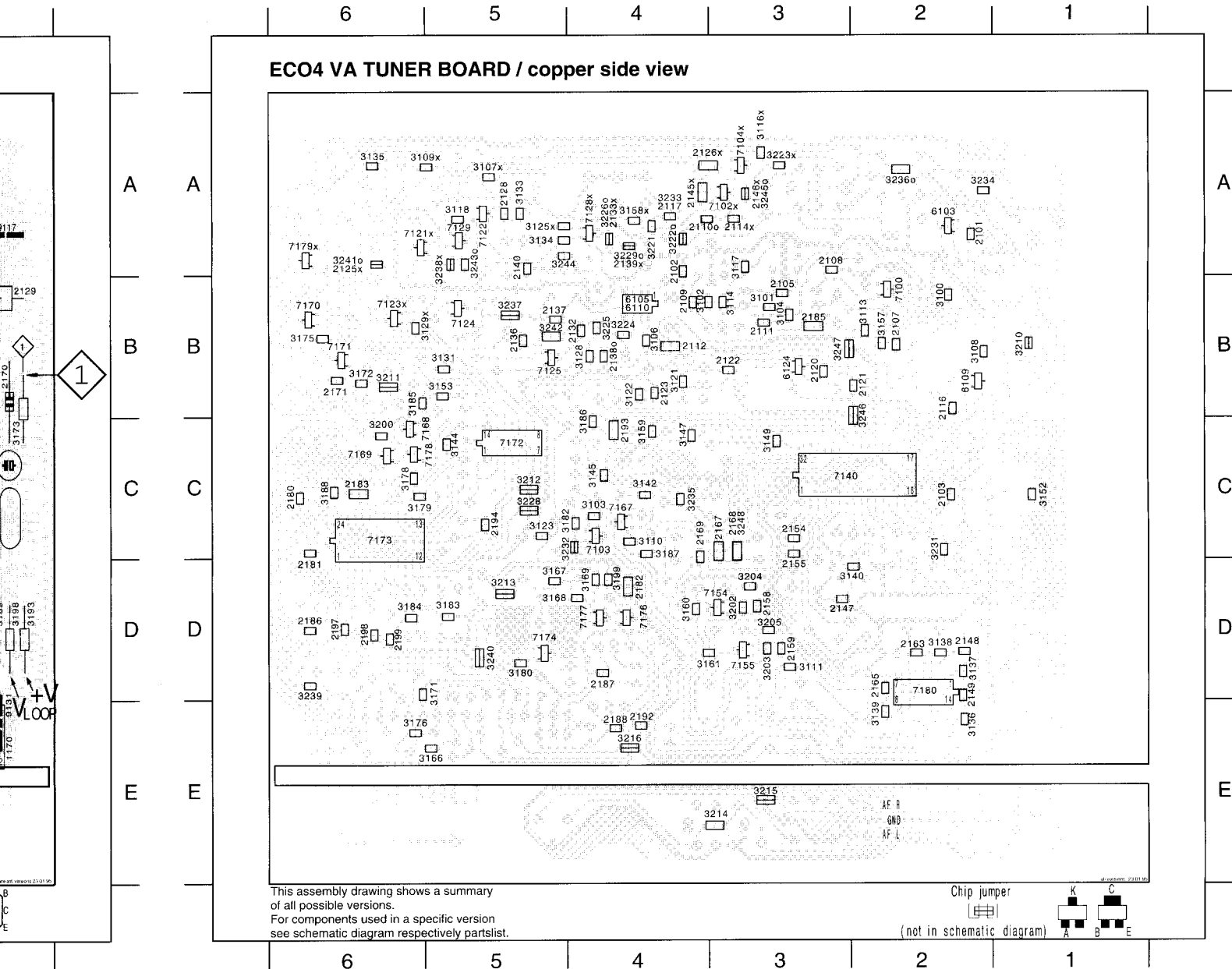


08 A 2
09 A 3

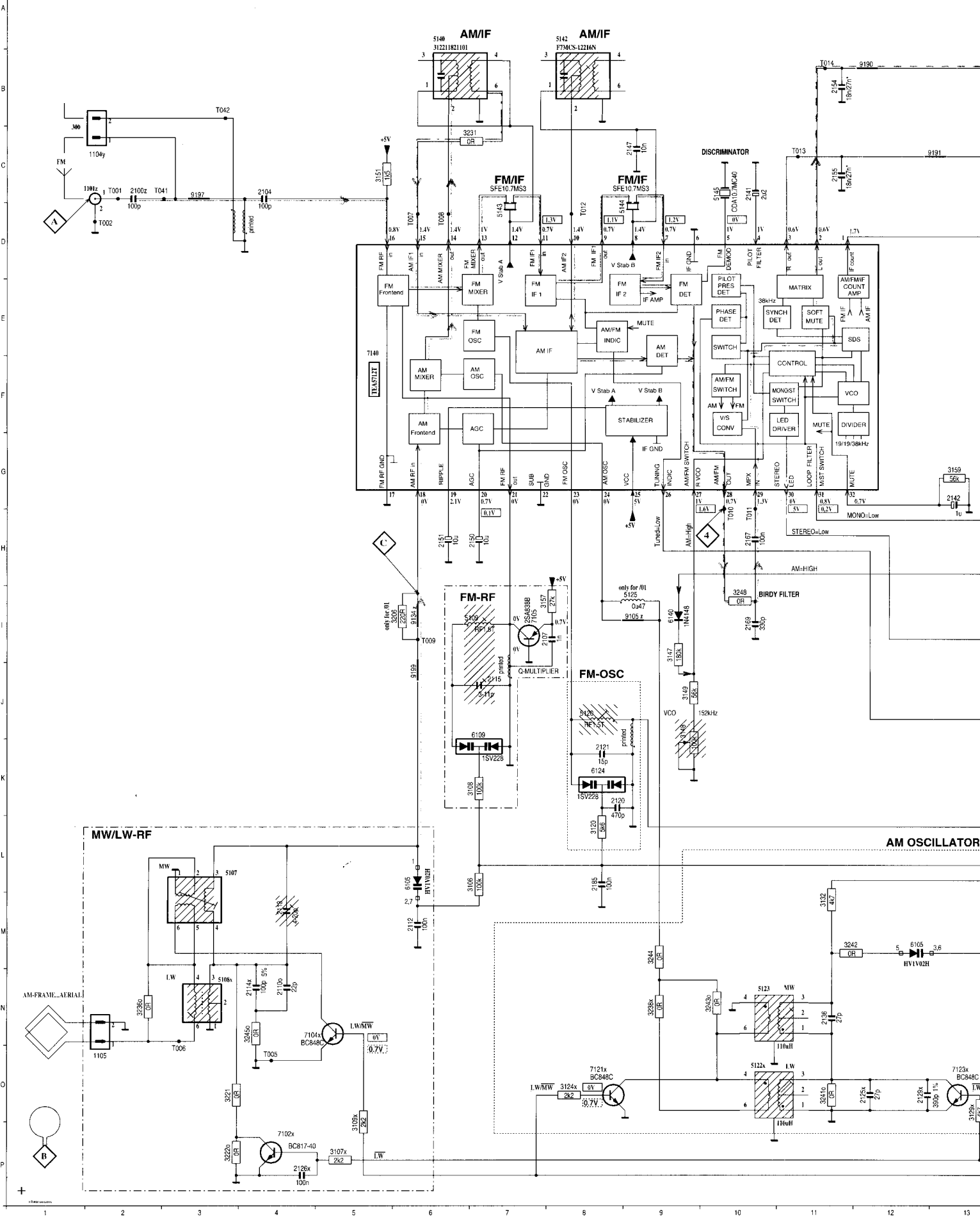
2101 A 2	2122 B 3	2148 D 2	2183 C 6	3104 B 3	3125x A 5	3147 C 4	3175 B 6	3203 D 3	3226o A 4	3243o A 5	7121x A 6	7172 C 5
2102 A 4	2123 B 4	2149 D 2	2185 B 3	3106 B 4	3128 B 4	3149 C 3	3176 E 6	3204 D 3	3228 C 5	3244 A 5	7122 A 5	7173 C 6
2103 C 2	2125x A 6	2154 C 3	2186 D 6	3107x A 5	3129x B 6	3152 C 1	3178 C 6	3205 D 3	3229o A 4	3245o A 3	7123x B 6	7174 D 5
2105 B 3	2126x A 3	2155 C 3	2187 D 4	3108 B 2	3131 B 5	3153 B 5	3179 C 6	3210 B 1	3231 C 2	3246 B 2	7124 B 5	7176 D 4
2107 B 2	2128 A 5	2158 D 3	2188 E 4	3109x A 5	3133 A 5	3157 B 2	3180 D 5	3211 B 6	3232 C 4	3247 B 3	7125 B 5	7177 D 4
2108 A 3	2132 B 4	2159 D 3	2192 E 4	3110 C 4	3134 A 5	3158x A 4	3182 C 4	3212 C 5	3233 A 4	3248 C 3	7128x A 4	7178 C 6
2109 B 4	2133x A 4	2163 D 2	2193 C 4	3111 D 3	3135 A 6	3159 C 4	3183 D 5	3213 D 5	3234 A 2	6103 A 2	7129 A 5	7179x A 6
2110o A 4	2136 B 5	2165 E 2	2194 C 5	3113 B 2	3136 E 2	3160 D 4	3184 D 6	3214 E 3	3235 C 4	6105 B 4	7140 C 2	7180 D 2
2111 B 3	2137 B 5	2167 C 3	2197 D 6	3114 B 3	3137 D 2	3161 D 3	3185 B 6	3215 E 3	3236o A 2	6109 B 2	7154 D 3	
2112 B 4	2138o A 4	2168 C 3	2198 D 6	3116x A 3	3138 D 2	3166 E 5	3186 C 4	3216 E 4	3237 B 5	6110 B 4	7155 D 3	
2114x A 3	2139x A 4	2169 C 4	2199 D 6	3117 A 3	3139 D 2	3167 D 5	3187 C 4	3221 A 4	3238x A 5	6124 B 3	7167 C 4	
2116 B 2	2140 A 5	2171 B 6	3100 B 2	3118 A 5	3140 D 2	3168 D 4	3188 C 6	3222o A 4	3239 D 6	7100 B 2	7168 C 6	
2117 A 4	2145x A 4	2180 C 6	3101 B 3	3121 B 4	3142 C 4	3169 D 4	3199 D 4	3223x A 3	3240 D 5	7102x A 3	7169 C 6	
2120 B 3	2146x A 3	2181 C 6	3102 B 3	3122 B 4	3144 C 5	3171 D 6	3200 C 6	3224 B 4	3241o A 6	7103 C 4	7170 B 6	
2121 B 2	2147 D 3	2182 D 4	3103 C 4	3123 C 5	3145 C 4	3172 B 6	3202 D 3	3225 B 4	3242 B 5	7104x A 3	7171 B 6	

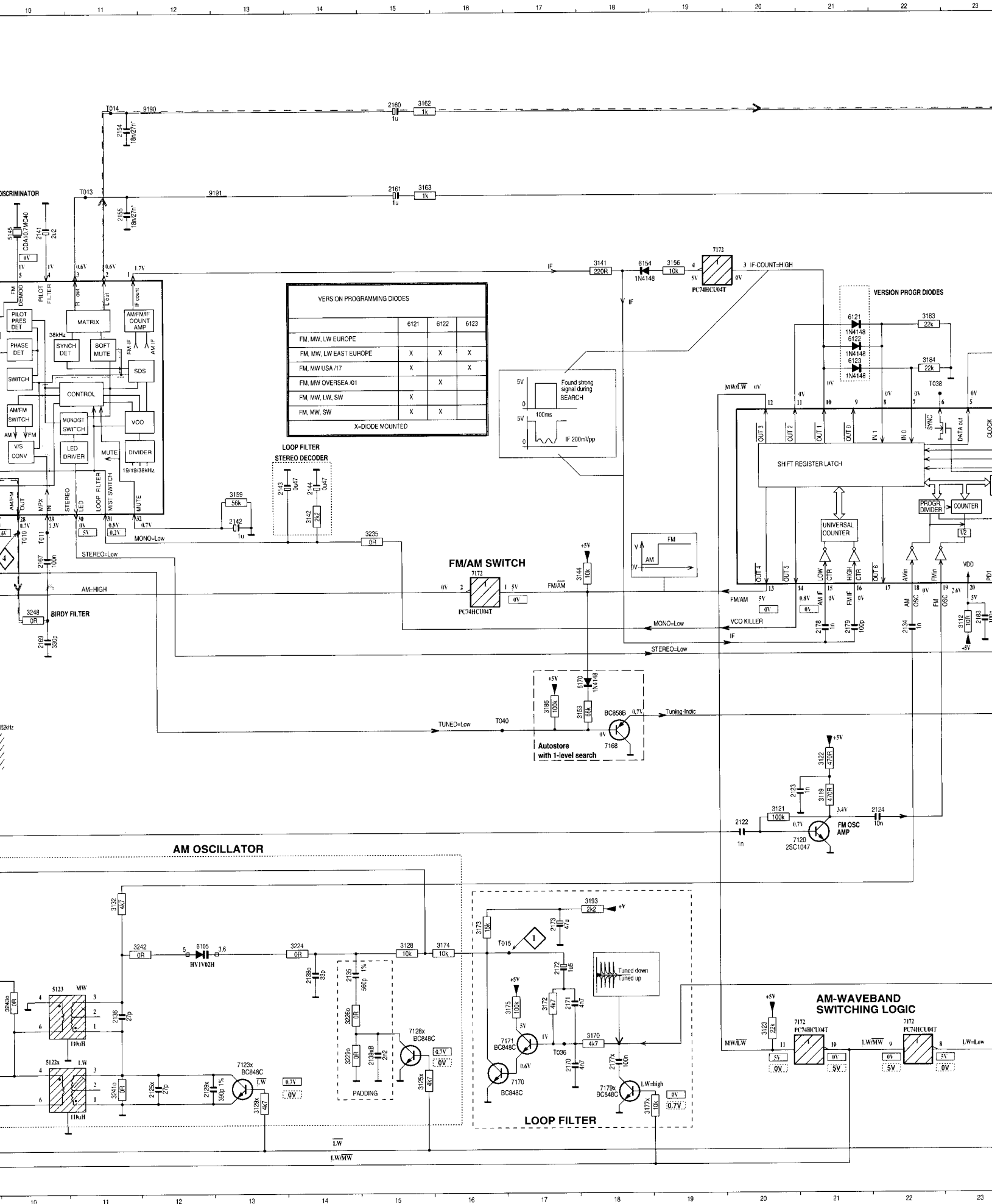
o for AM-version only
x for LW-version only
y for USA version only
z not for all versions

o for AM-version only
x for LW-version only
y for USA version only
z not for all versions



TUNER UNIT ECO4-VA (MINI)

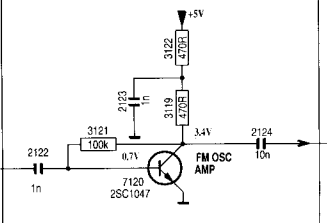
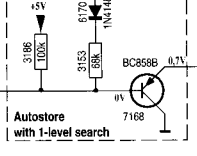
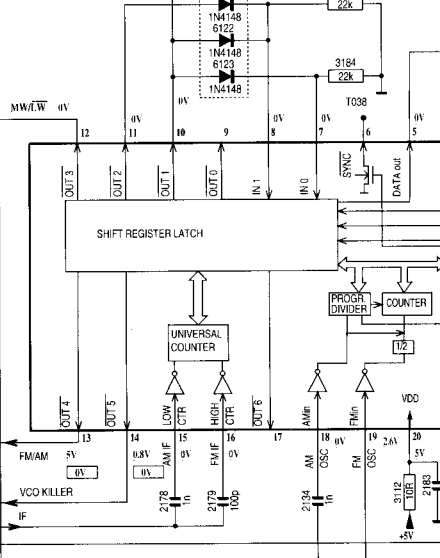
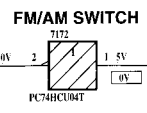
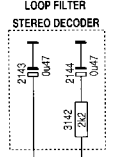
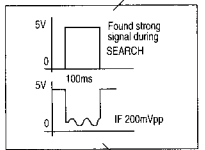




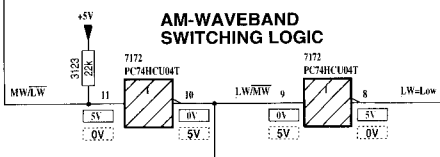
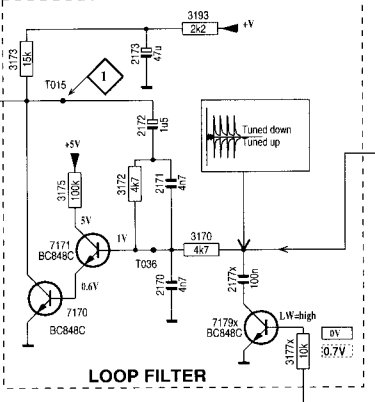
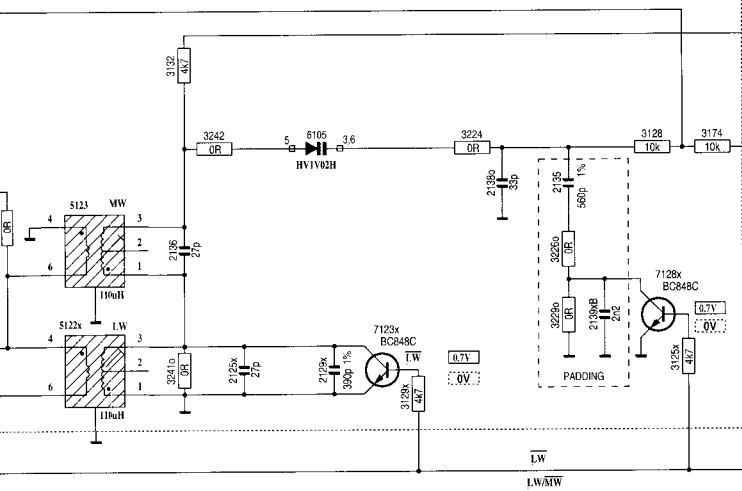
VERSION PROGRAMMING DIODES

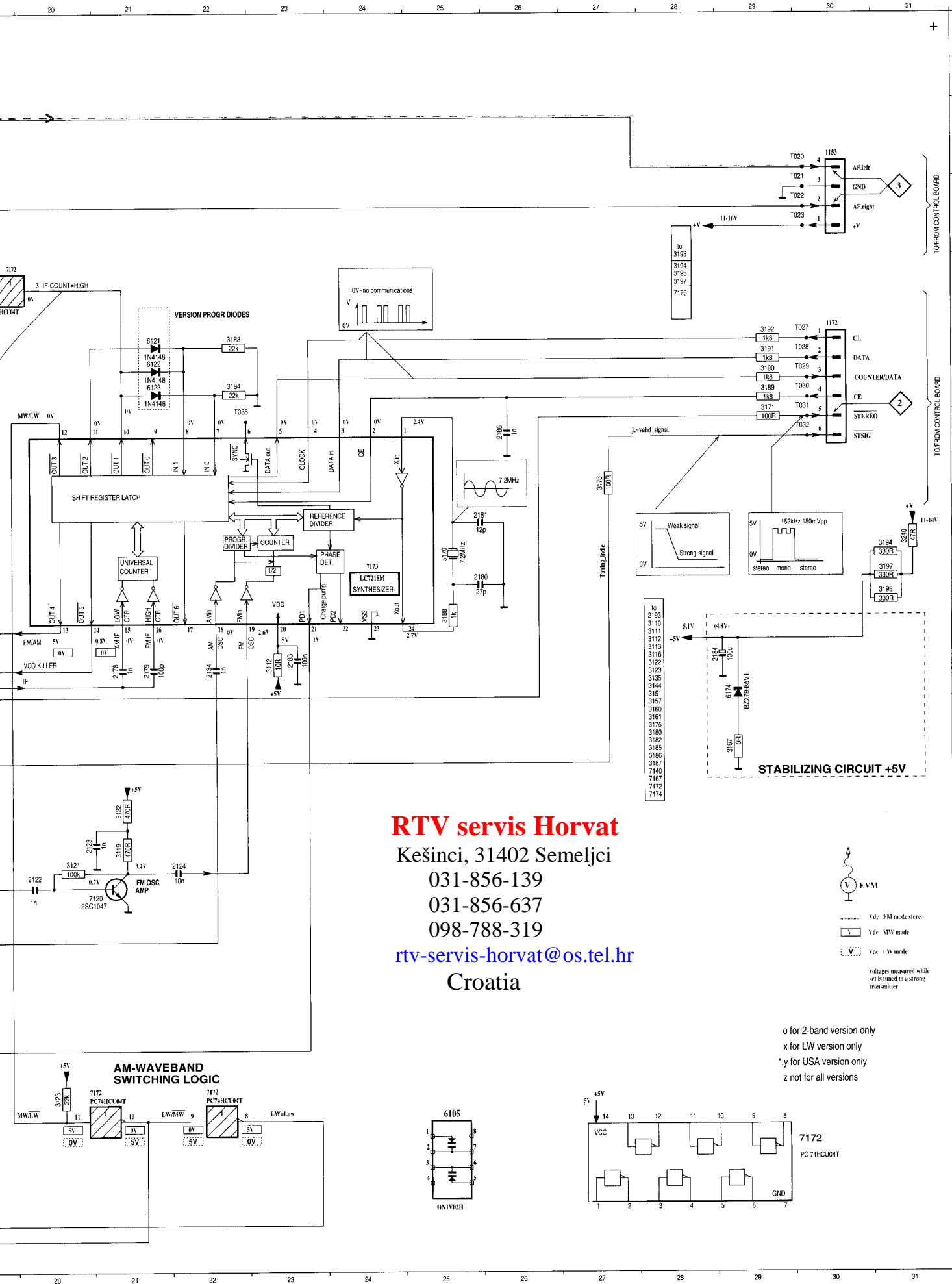
	6121	6122	6123
FM, MW, LW EUROPE			
FM, MW, LW EAST EUROPE	X	X	X
FM, MW USA /17	X		X
FM, MW OVERSEA /01		X	
FM, MW, LW, SW	X		
FM, MW, SW	X	X	

X-DIODE MOUNTED



AM OSCILLATOR





RTV servis Horvat

Kešinci, 31402 Semeljci

031-856-139

031-856-637

098-788-319

rtv-servis-horvat@os.tel.hr

Croatia



o for 2-band version only
 x for LW version only
 *y for USA version only
 z not for all versions

A	1101z C 1	T001 C 2
	1104x C 2	T002 C 2
	1105 C 2	T005 O 4
	1153 B30	T006 O 3
	1172 D30	T007 D 6
	T008 C 2	T008 D 8
	2104 C 4	T009 I 6
	2107 I 8	T010 H 0
	2110x N 4	T011 H 0
	2112 N 6	T012 C 8
	2113 M 4	T013 C 11
	2114x N 4	T014 B 11
	2115 L 7	T015 M 16
	2120 K 8	T020 B 9
	2121 K 9	T021 C 9
	2122 K 0	T022 C 29
	2123 K 20	T023 C 29
	2124 K 22	T027 D 30
	2125x O 12	T028 E 30
	2126x P 4	T029 E 30
	2129x O 12	T030 E 30
	2134 I 2	T031 H 10
	2135 M 14	T032 F 30
	2136 N 11	T033 F 30
	2138x N 14	T036 O 17
	2139x O 15	T038 F 22
	2141 C 10	T040 J 13
	2142 G 13	T041 C 2
	2143 G 13	T042 B 3
	2144 G 14	
	2147 C 9	
	2150 H 7	
	2151 H 6	
	2154 C 11	
	2155 C 12	
	2156x O 15	
	2159 H 10	
	2160 H 10	
	2170 O 17	
	2171 N 17	
	2172 M 17	
	2173 M 17	
	2177x O 18	
	2178 I 21	
	2179 I 21	
	2180 H 25	
	2181 G 25	
	2183 I 23	
	2184 I 29	
	2185 L 8	
	2186 F 26	
	3102 L 7	
	3107x P 5	
	3108 K 7	
	3109x O 5	
	3122 K 21	
	3123 N 20	
	3124x O 8	
	3125x O 15	
	3128 M 15	
	3129x O 13	
	3132 M 12	
	3141 D 18	
	3142 G 14	
	3144 I 18	
	3147 I 9	
	3148 J 9	
	3149 J 9	
	3151 C 4	
	3153 J 18	
	3156 I 19	
	3157 I 7	
	3159 G 13	
	3162 B 15	
	3163 O 15	
	3167 I 29	
	3170 N 18	
	3171 N 18	
	3172 N 17	
	3173 M 16	
	3174 M 16	
	3175 N 17	
	3176 F 27	
	3177x O 18	
	3184 E 22	
	3185 J 17	
	3188 H 25	
	3189 E 29	
	3190 E 29	
	3181 E 29	
	3182 E 29	
	3183 M 18	
	3184 G 31	
	3185x O 1	
	3187 H 31	
	3206 I 6	
	3221 O 3	
	3222x P 3	
	3224 M 14	
	3226x N 14	
	3228x O 14	
	3231 C 7	
	3235 H 15	
	3236x N 2	
	3238x N 9	
	3240 G 31	
	3241x O 11	
	3242 N 11	
	3243x N 10	
	3244 M 9	
	3245x N 4	
	3248 I 10	
	5107 M 2	
	5108x N 3	
	5109 I 7	
	5120 J 8	
	5122x O 10	
	5123 N 10	
	5125 I 9	
	5140 A 6	
	5142 A 6	
	5143 O 7	
	5144 D 9	
	5145 C 10	
	5170 C 25	
	6105 M 12	
	6109 I 7	
	6121 E 21	
	6122 E 21	
	6123 E 21	
	6124 K 8	
	6140 I 9	
	6154 D 18	
	6170 J 18	
	6174 I 29	
	7102x P 4	
	7104x N 5	
	7105 I 7	
	7120 L 20	
	7121x O 8	
	7122x O 13	
	7128x N 15	
	7140 E 5	
	7168 J 18	
	7170 O 17	
	7171 H 16	
	7172 I 30	
	7172 O 20	
	7172 N 22	
	7172 N 23	
	7172 O 22	
	7173 H 24	
	7178x O 18	
	9105 I 9	
	9134 I 6	
	9190 I 12	
	9191 C 13	
	9197 C 3	
	9199 J 6	

ELECTRICAL PARTSLIST TUNER ECO4VA BOARD

ELECTRICAL

MISCELLANEOUS

1101	4822 267 10283	SOCKET COAX IEC 75R
1105	4822 265 31184	JST CONNECTOR 2 POLE

DIODES

6105	4822 130 83075	HN1V02H
6109	4822 130 82833	1SV228
6122	4822 130 30621	1N4148
6124	4822 130 82833	1SV228
6140	4822 130 30621	1N4148

6154	4822 130 30621	1N4148
6170	4822 130 30621	1N4148
6174	4822 130 34233	BZX79-B5V1

TRANSISTORS

7105	4822 130 60093	2SA838B
7120	4822 130 60163	2SC1047
7168	5322 130 41983	BC858B(CHIP)
7170	5322 130 42136	BC848C(CHIP)
7171	5322 130 42136	BC848C(CHIP)

INTEGRATED CIRCUITS

7140	4822 209 32701	TEA5712T/N2 (RF IC)
7172	5322 209 11517	PC74HCU04T
7173	4822 209 31998	LC7218M SYNTHESIZER

COILS

5107	4822 157 63835	ANT. COIL MW 2-BAND
5109	4822 156 30947	RF COIL 1,5 TURNS
5120	4822 156 30947	RF COIL 1,5 TURNS
5123	4822 157 60517	110µH 8%
5125	4822 157 61898	0,47µH

5140	4822 158 60511	AM-IF FILTER 450kHz
5142	4822 157 70302	AM-IF FILTER 450kHz
5143	4822 242 70665	CER. FILTER 10,7MHZ
5144	4822 242 70665	CER. FILTER 10,7MHZ
5145	4822 242 81362	CER. DISCRIMINATOR

5170	4822 242 72976	CER. RESONATOR 7,2MHZ
------	----------------	-----------------------

RESISTORS

3112	4822 116 52176	10R	5%	0,5W
3119	4822 116 52224	470R	5%	0,5W
3120	4822 116 52289	5k6	5%	0,16W
3132	4822 116 52283	4k7	5%	0,5W
3141	4822 116 52215	220R	5%	0,16W

3148	4822 100 11163	TRIMPOT.100k lin.		
3151	4822 116 52243	1k5	5%	0,16W
3156	4822 116 83864	10k	5%	0,5W
3162	4822 050 11002	1k	5%	0,2W
3163	4822 050 11002	1k	5%	0,2W

3170	4822 116 52283	4k7	5%	0,5W
3173	4822 116 52244	15k	5%	0,5W
3174	4822 116 83864	10k	5%	0,5W
3189	4822 116 52249	1k8	5%	0,16W
3190	4822 116 52249	1k8	5%	0,16W

3191	4822 116 52249	1k8	5%	0,16W
3192	4822 116 52249	1k8	5%	0,16W
3193	4822 116 52256	2k2	5%	0,16W
3194	4822 116 52219	330R	5%	0,5W
3195	4822 116 52219	330R	5%	0,5W

RESISTORS

3197	4822 116 52219	330R	5%	0,5W
3206	4822 116 52215	220R	5%	0,16W

CHIP RESISTORS

3106	4822 051 20104	100k	5%	0,1W
3108	4822 051 20104	100k	5%	0,1W
3121	4822 051 20104	100k	5%	0,1W
3122	4822 051 20471	470R	5%	0,1W
3123	4822 051 20223	22k	5%	0,1W

3128	4822 117 10833	10k	1%	0,1W
3142	4822 051 20222	2k2	5%	0,1W
3144	4822 117 10833	10k	1%	0,1W
3147	4822 051 20184	180k	5%	0,1W
3149	4822 051 20563	56k	5%	0,1W

3153	4822 051 20683	68k	5%	0,1W
3157	4822 051 20273	27k	5%	0,1W
3159	4822 051 20563	56k	5%	0,1W
3167	4822 051 20008	CHIP JUMPER 0805		
3171	4822 051 20101	100R	5%	0,1W

3172	4822 051 20472	4k7	5%	0,1W
3175	4822 051 20104	100k	5%	0,1W
3176	4822 051 20101	100R	5%	0,1W
3183	4822 051 20223	22k	5%	0,1W
3184	4822 051 20223	22k	5%	0,1W

3186	4822 051 20104	100k	5%	0,1W
3188	4822 051 10102	1k	2%	0,25W
3210	4822 051 20008	CHIP JUMPER 0805		
3211	4822 051 10008	CHIP JUMPER1206		
3212	4822 051 10008	CHIP JUMPER1206		

3213	4822 051 10008	CHIP JUMPER1206
3221	4822 051 20008	CHIP JUMPER 0805
3222	4822 051 20008	CHIP JUMPER 0805
3224	4822 051 20008	CHIP JUMPER 0805
3226	4822 051 20008	CHIP JUMPER 0805

3228	4822 051 10008	CHIP JUMPER1206
3229	4822 051 20008	CHIP JUMPER 0805
3231	4822 051 20008	CHIP JUMPER 0805
3235	4822 051 20008	CHIP JUMPER 0805
3236	4822 051 10008	CHIP JUMPER1206

3237	4822 051 10008	CHIP JUMPER1206
3240	4822 051 10479	47R
3241	4822 051 20008	CHIP JUMPER 0805
3242	4822 051 10008	CHIP JUMPER1206
3243	4822 051 20008	CHIP JUMPER 0805

3244	4822 051 20008	CHIP JUMPER 0805
3246	4822 051 10008	CHIP JUMPER1206
3247	4822 051 10008	CHIP JUMPER1206
3248	4822 051 10008	CHIP JUMPER1206

CAPACITORS

2100	4822 122 33195	100pF	10%	50V
2104	4822 122 33195	100pF	10%	50V
2113	4822 125 50355	4,2-20pF	VARIABLE	
2115	4822 125 60101	10pF	VARIABLE	
2124	4822 121 51387	10nF	20%	16V

2134	4822 122 33197	1nF	10%	50V
2135	4822 121 70245	560pF	1%	160V
2141	4822 124 40244	2,2µF	20%	63V
2142	4822 124 40242	1µF	20%	63V
2143	4822 124 40239	0,47µF	20%	63V

CAPACITORS

2144
2150
2151
2160
2161

2170
2172
2173
2178
2179

2184

CHIP CAPACITORS

2107
2112
2120
2121
2122

2123

2136

2138

2147

2154

2155

2167

2169

2171

2180

2181

2183

2185

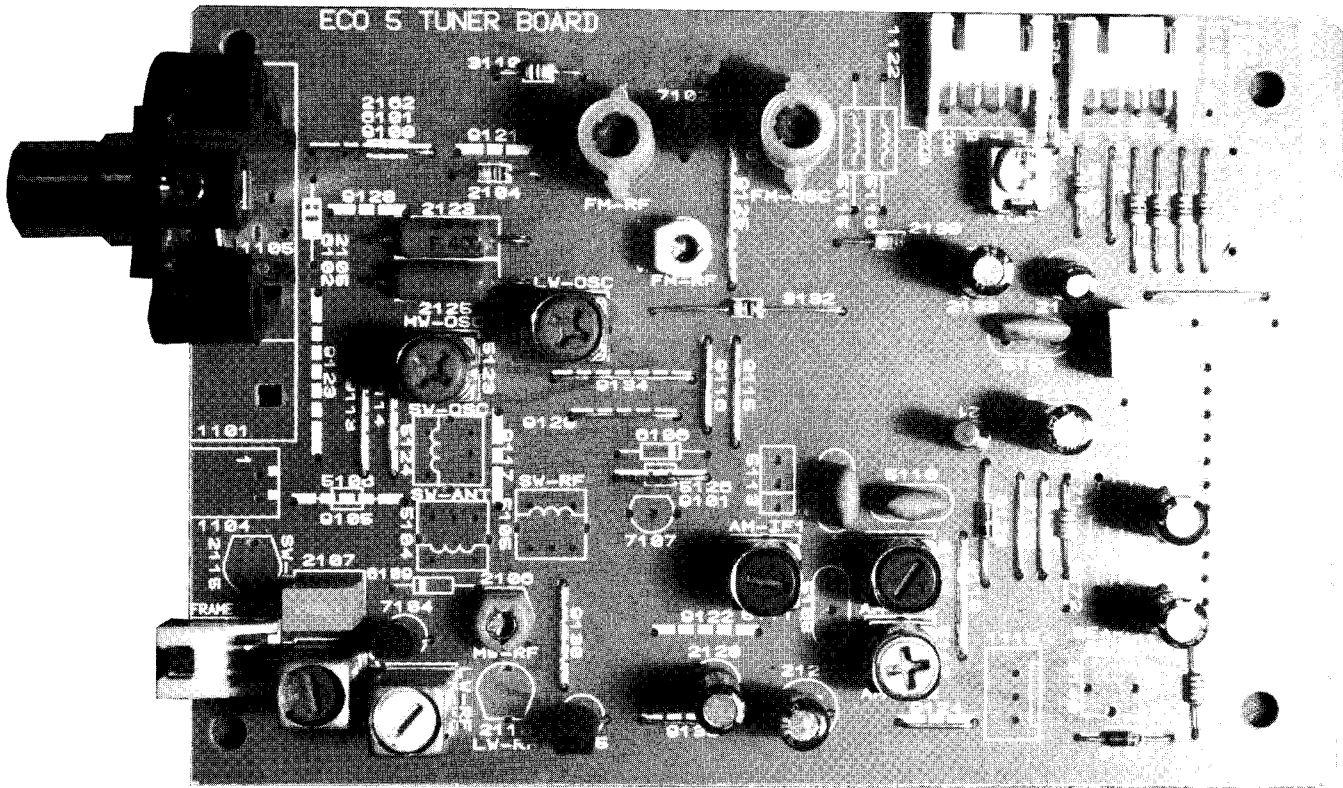
2186

ELECTRICAL PARTSLIST TUNER ECO4VA BOARD**CAPACITORS**

2144	4822 124 40239	0,47 μ F	20%	63V
2150	4822 124 40248	10 μ F	20%	63V
2151	4822 124 40248	10 μ F	20%	63V
2160	4822 124 40242	1 μ F	20%	63V
2161	4822 124 40242	1 μ F	20%	63V
2170	4822 126 11714	4,7nF	20%	
2172	4822 124 41631	1,5 μ F	20%	50V
2173	4822 124 40433	47 μ F	20%	25V
2178	4822 122 33197	1nF	10%	50V
2179	4822 122 33195	100pF	10%	50V
2184	4822 124 41584	100 μ F	20%	10V

CHIP CAPACITORS

2107	5322 122 34123	1nF	10%	50V
2112	4822 122 33496	100nF	10%	63V
2120	5322 122 32268	470pF	10%	50V
2121	5322 122 32481	15pF	5%	50V
2122	5322 122 34123	1nF	10%	50V
2123	5322 122 34123	1nF	10%	50V
2136	5322 122 31946	27pF	5%	50V
2138	5322 122 32659	33pF	5%	50V
2147	4822 122 33177	10nF	20%	50V
2154	4822 122 33893	18nF	10%	63V
2155	4822 122 33893	18nF	10%	63V
2167	4822 122 33496	100nF	10%	63V
2169	5322 122 31863	330pF	5%	50V
2171	5322 126 10223	4,7nF	10%	63V
2180	5322 122 31946	27pF	5%	50V
2181	4822 122 32139	12pF	5%	63V
2183	4822 122 33496	100nF	10%	63V
2185	4822 122 33496	100nF	10%	63V
2186	5322 122 34123	1nF	10%	50V



TUNER BOARD ECO5

AM-FRAME



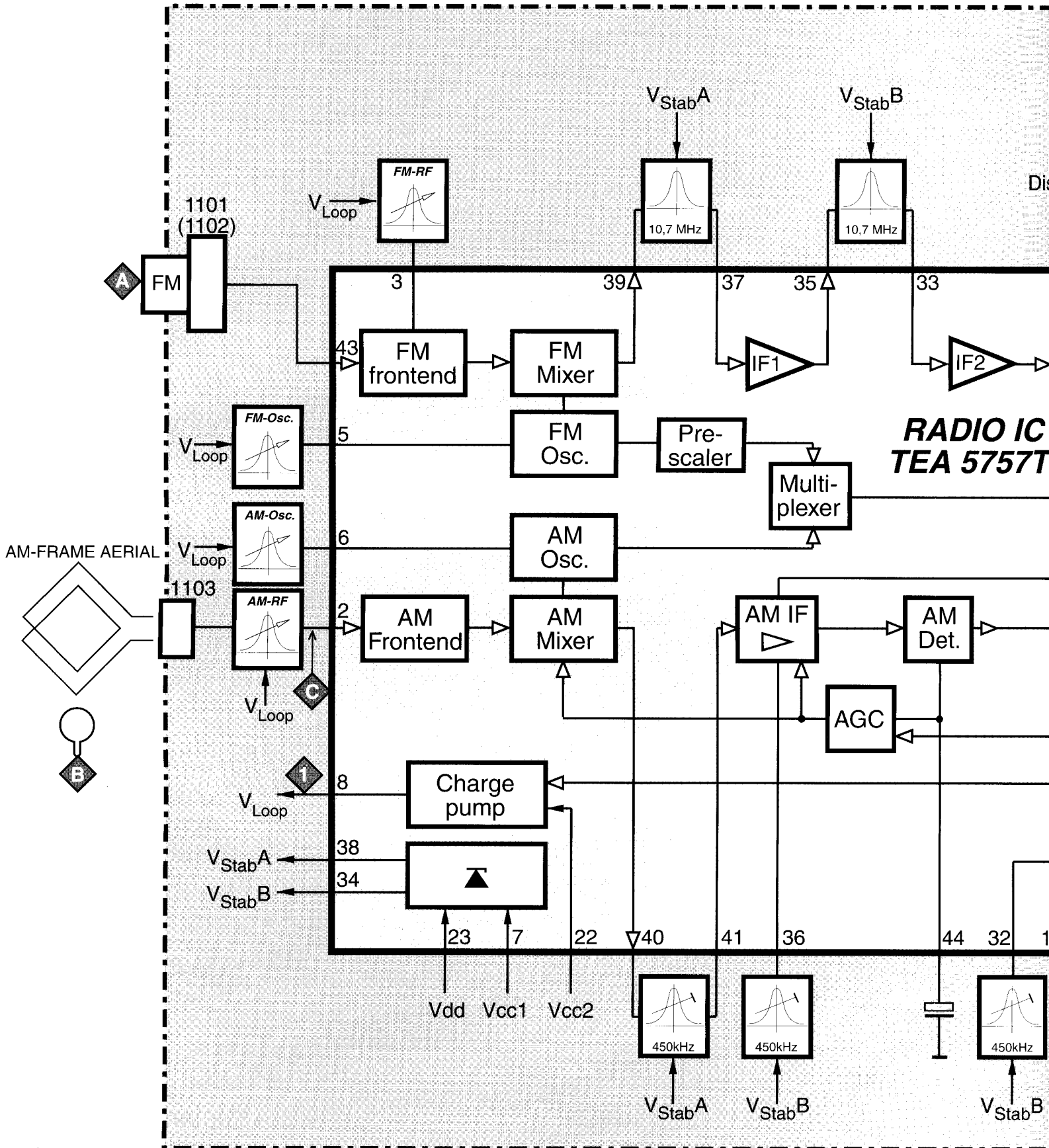
TABLE OF CONTENTS

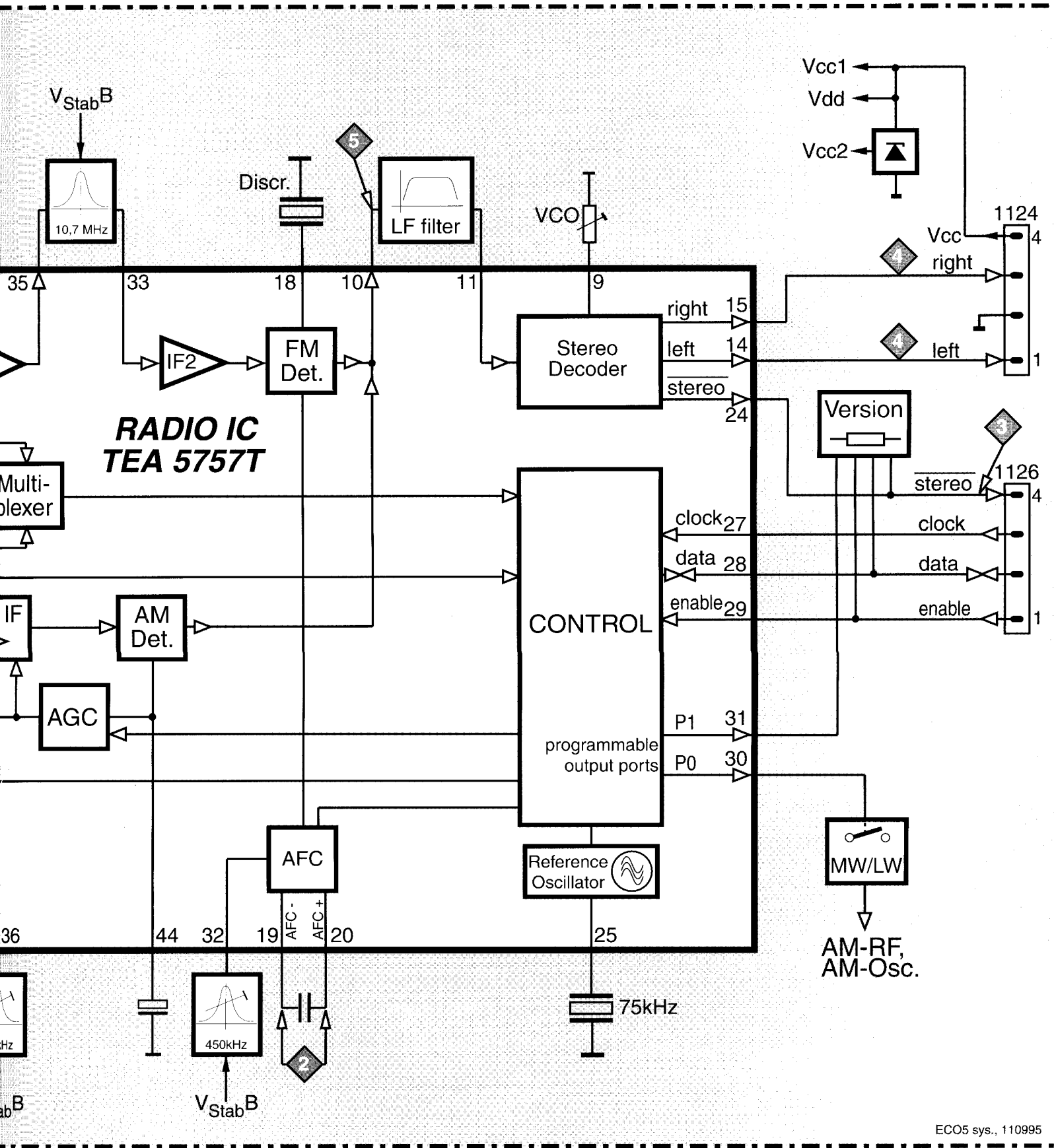
Blockdiagram7B-1
 Adjustmant table7B-2
 Component layout7B-2
 Circuit diagram7B-3
 Partslist7B-4

BLOCKDIAGRAM

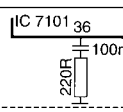
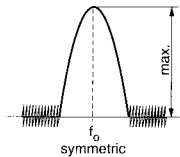
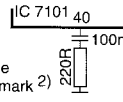

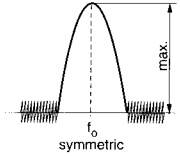
TUNER BOARD

ECO 5 systems





TUNER ADJUSTMENT TABLE (ECO5 FM/MW- and FM/MW/LW - versions with AM-frame aerial)

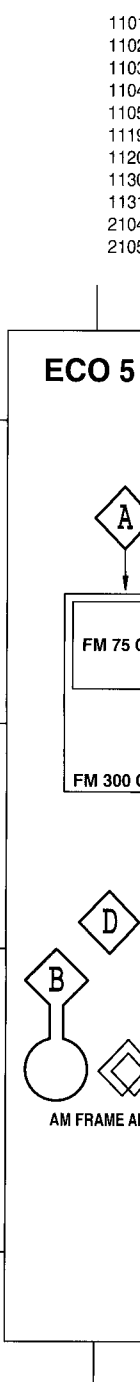
Waverange	Input frequency	Input	Tuned to	Adjust	Output	Scope/Voltmeter
<i>VARICAP ALIGNMENT</i>						
FM 87.5 - 108MHz			108MHz	5130	1	8V ±0.2V
			87.5MHz	check		4.3V ±0.5V
MW FM/AM-version, 10kHz grid 530 - 1700kHz			1700kHz	5123		8V ±0.2V
			530kHz	check		1.1V ±0.4V
LW 153 - 279kHz			279kHz	5122		8V ±0.2V
			153kHz	check		1.1V ±0.4V
MW FM/MW/LW- and FM/MW-version (9kHz grid) 531 - 1602kHz			1602kHz	5123		8V ±0.2V
			531kHz	check		1.1V ±0.4V
<i>FM RF</i>						
FM 87.5 - 108MHz	108MHz	A	108MHz	2155	4	MAX
	87.5MHz	mod=1kHz Δf=±22.5kHz	87.5MHz	5131		
<i>VCO</i>						
FM	98MHz, 1mV continuous wave	A	98MHz	3142	3	152kHz ±1kHz ¹⁾
<i>AM IF</i>						
MW	450kHz connect pin 26 of IC 7101 (AM Osc.) with short wire to ground (pin 4)	C		5111	4	
				5112		
AM AFC MW		C		5114	2	0 ± 2 mV DC
<i>AM RF ³⁾</i>						
MW ⁴⁾ FM/MW/LW- and FM/MW-version (9kHz grid) 531 - 1602kHz	1494kHz	B 	1494kHz	2106	4	
	558kHz		558kHz	5102		
LW	198kHz		198kHz	5103		
MW FM/AM-version, 10kHz grid 530 - 1700kHz	1500kHz		Δf = ±30kHz V _{RF} as low as possible	1500kHz		
	560kHz	560kHz		5102		

Use service test program. By selecting the TUNER TEST test frequencies will be stored as preset frequencies automatically.

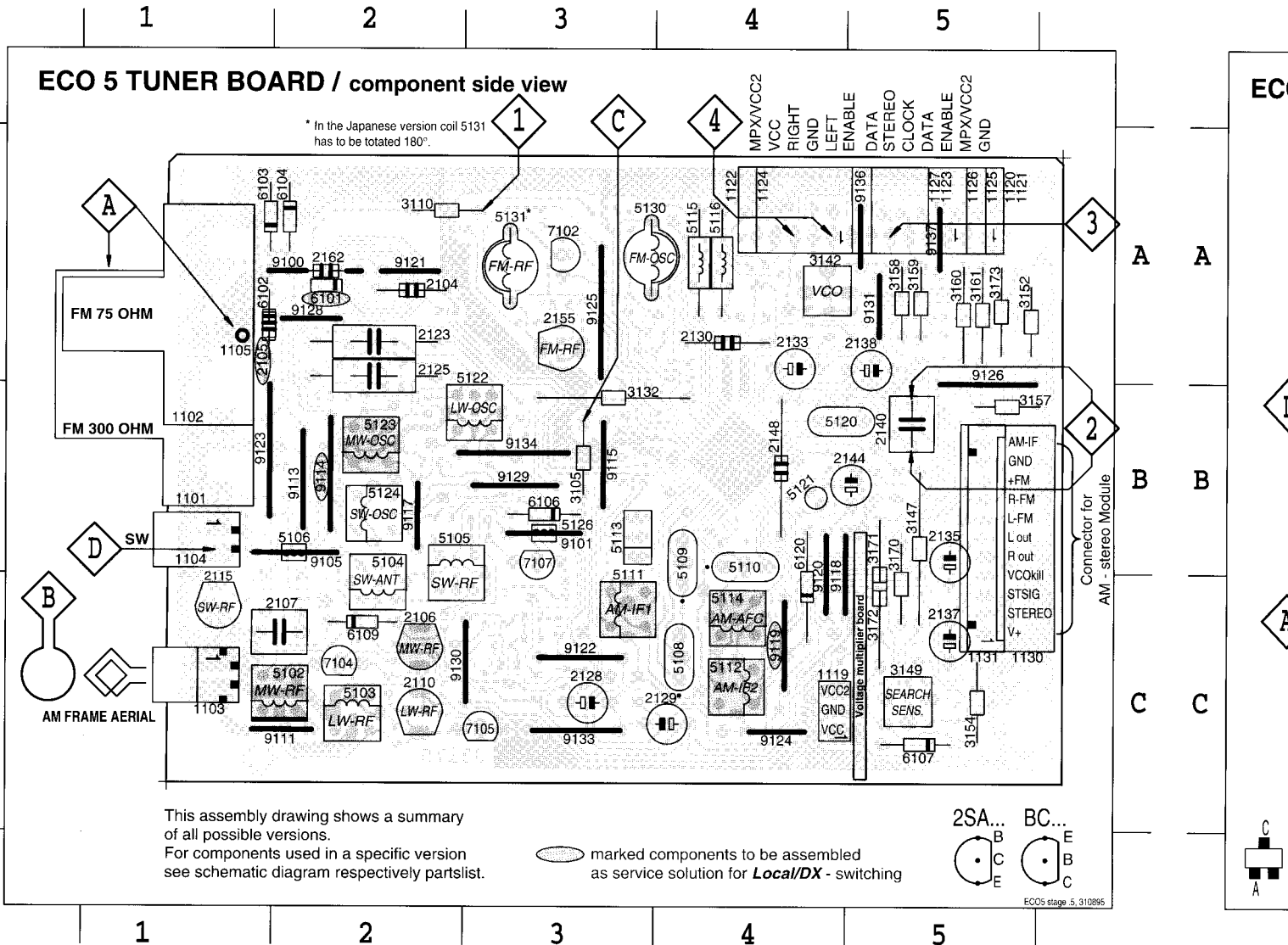
- ¹⁾ If sensitivity of frequency counter is too low adjust to max. channel separation (input signal: stereo left 90% + 9%, adjust output on right channel to minimum)
- ²⁾ RC network serves for damping the IF-filter while adjusting the other one.
- ³⁾ For AM RF adjustments the original frame antenna has to be used !
- ⁴⁾ MW has to be aligned before LW.

↑ Repeat

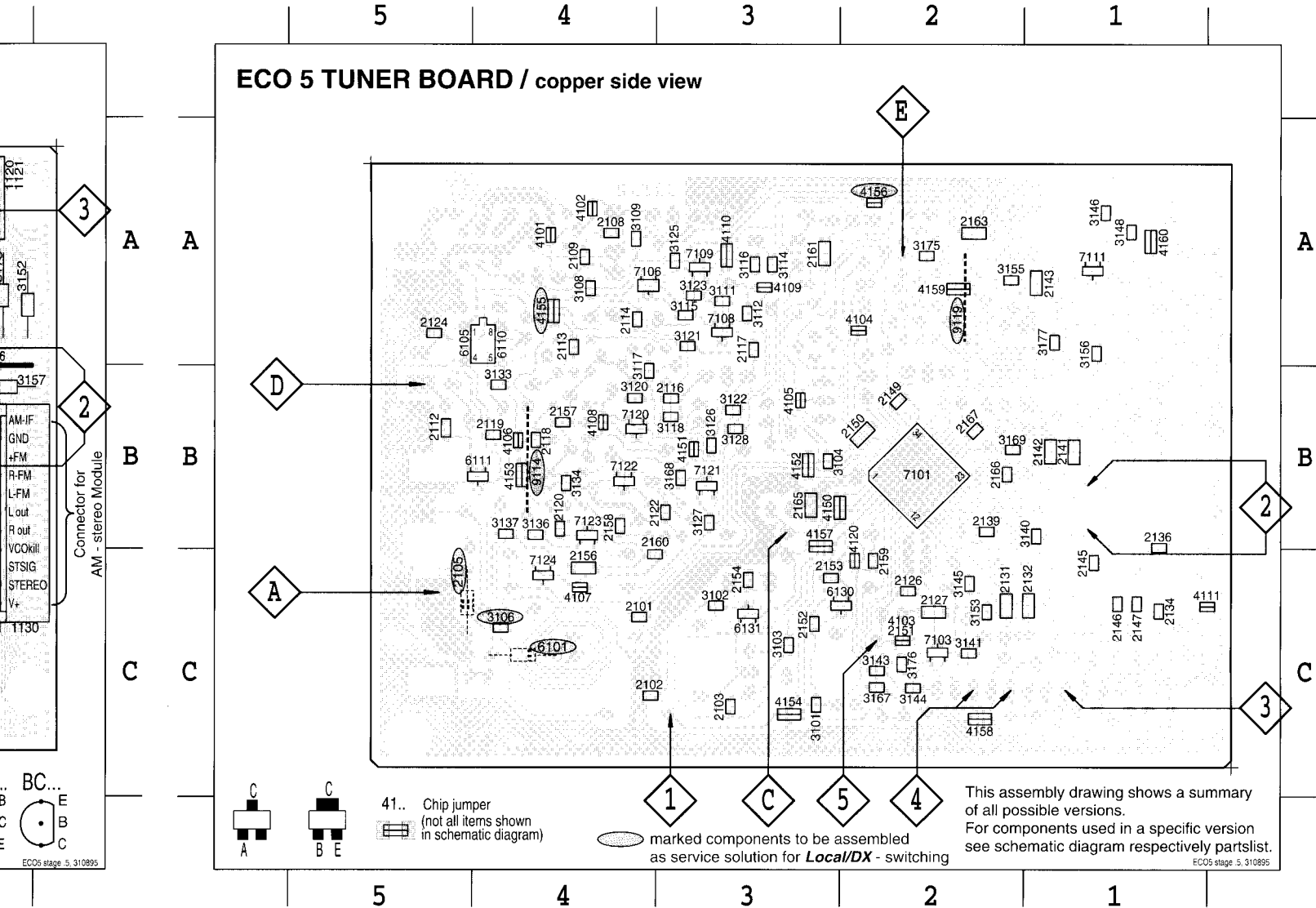
ECO5. 020995



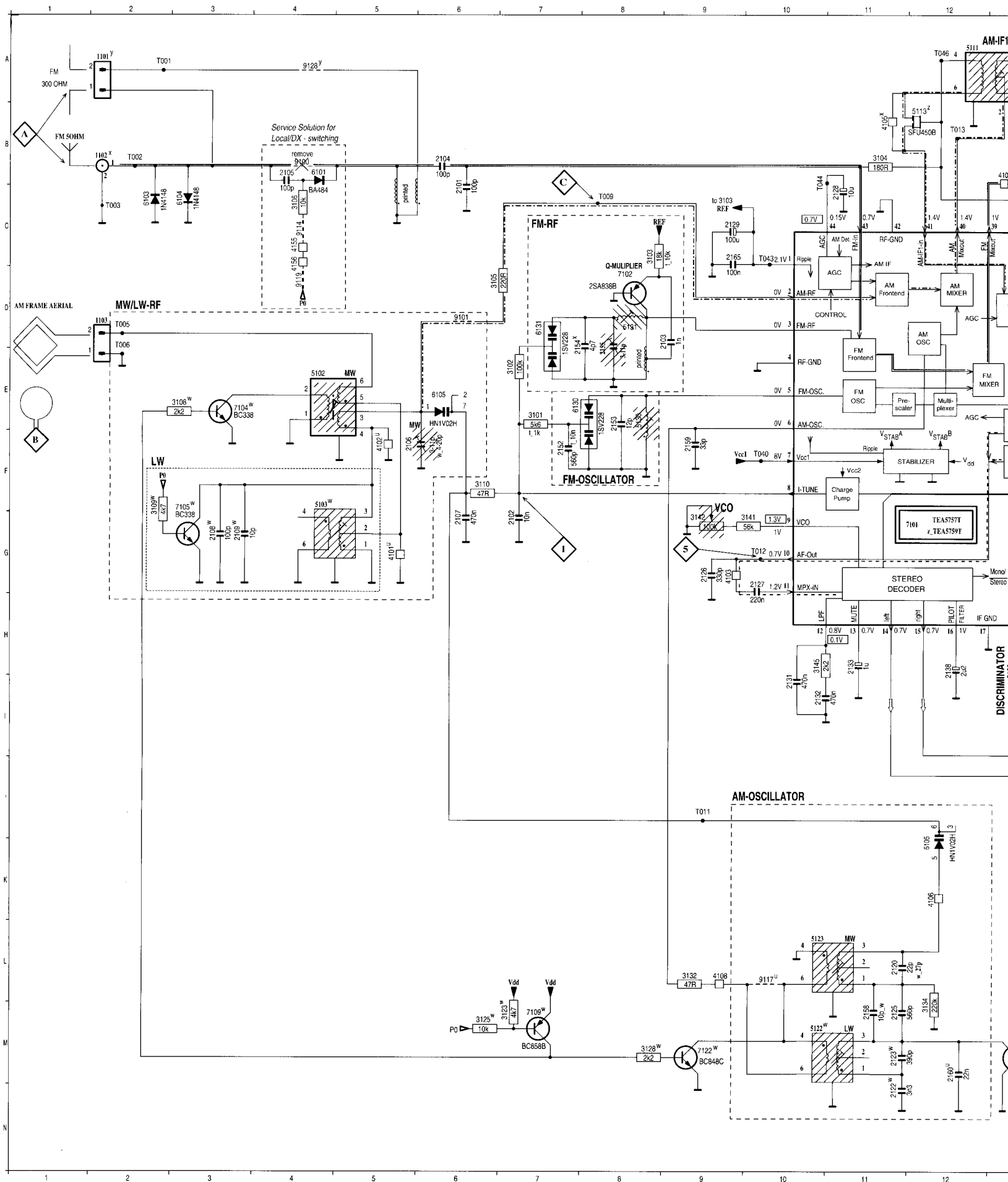
1101 A1	2106 C2	2137 C5	3147 B5	3172 C5	5112 C4	5130 A3	7104 C2	9118 B4	9130 C3	2101 C4
1102 A1	2107 C2	2138 A5	3149 C5	3173 A5	5113 B3	5131 A3	7105 C3	9119 C4	9131 A5	2102 C4
1103 C1	2110 C2	2140 B5	3152 A5	5102 C2	5114 C4	6101 A2	7107 B3	9120 B4	9133 C3	2103 C3
1104 B1	2115 C1	2144 B5	3154 C5	5103 C2	5115 A4	6102 A1	9100 A2	9121 A2	9134 B3	2108 A4
1105 A1	2123 A2	2148 B4	3157 B5	5104 C2	5116 A4	6103 A1	9101 B3	9122 C3	9136 A5	2109 A4
1119 C5	2125 A2	2155 A3	3158 A5	5105 B2	5120 B4	6104 A2	9105 B2	9123 B1	9137 A5	2112 B5
1120 A5	2128 C3	2162 A2	3159 A5	5106 B2	5121 B4	6106 B3	9111 C2	9124 C4		2113 A4
1130 B5	2129 C4	3105 B3	3160 A5	5108 C4	5122 B3	6107 C5	9113 B2	9125 A3		2114 A4
1131 B5	2130 A4	3110 A2	3161 A5	5109 B4	5123 B2	6109 C2	9114 B2	9126 B5		2116 B3
2104 A2	2133 A4	3132 B3	3170 C5	5110 B4	5124 B2	6120 C4	9115 B3	9128 A2		2117 A3
2105 A1	2135 B5	3142 A4	3171 C5	5111 C3	5126 B3	7102 A3	9117 B2	9129 B3		2118 B4

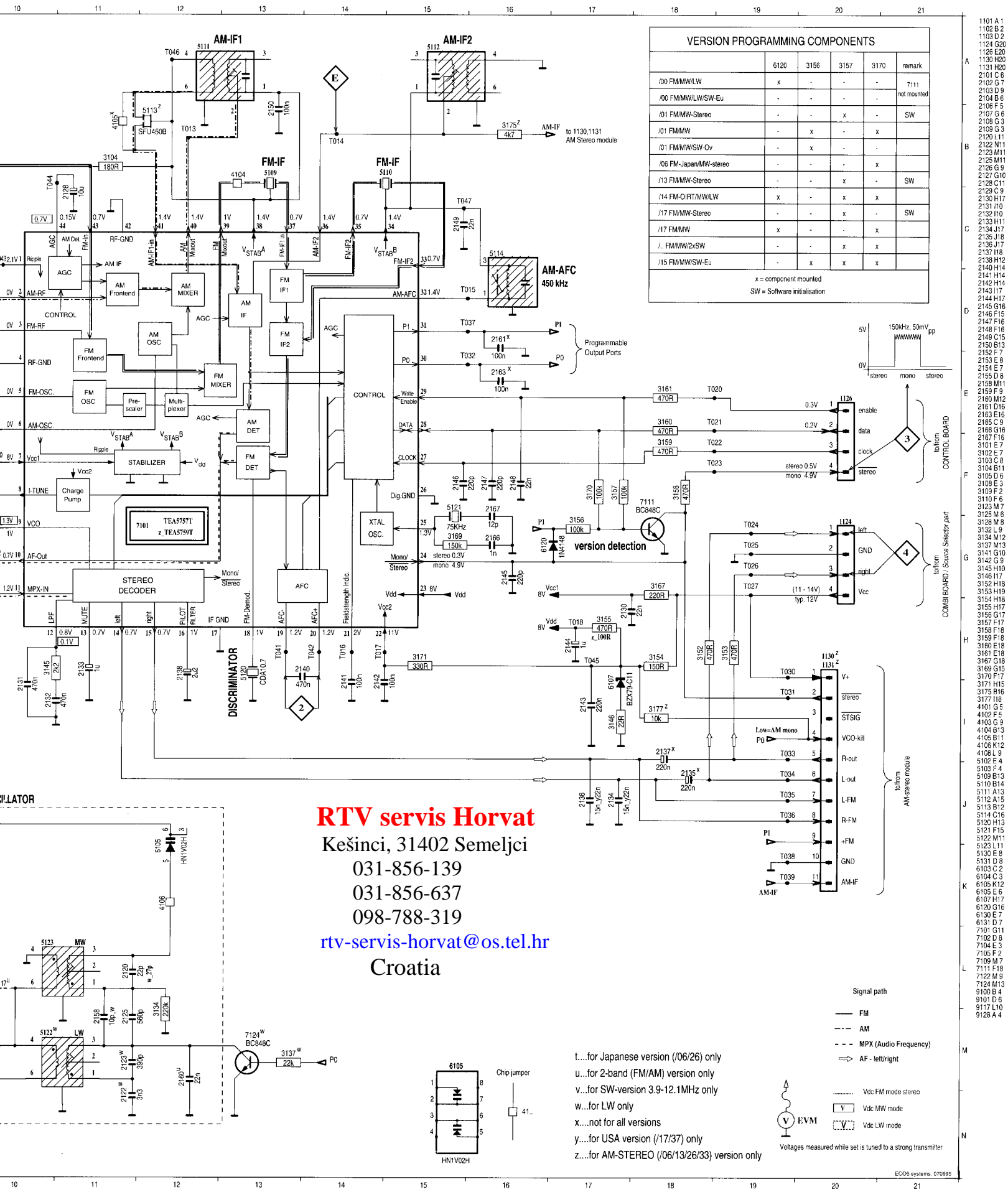


0 C3	2101 C4	2119 B4	2141 B1	2154 C3	3101 C3	3116 A3	3133 B4	3153 C2	4103 C2	4151 B3	6110 A4	7121 B3
1 A5	2102 C4	2120 B4	2142 B1	2156 C4	3102 C3	3117 B4	3134 B4	3155 A2	4104 A2	4152 B3	6111 B4	7122 B4
3 C3	2103 C3	2122 B3	2143 A1	2157 B4	3103 C3	3118 B3	3136 B4	3156 A1	4105 B3	4153 B4	6130 C2	7123 B4
4 B3	2108 A4	2124 A5	2145 C1	2158 B4	3104 B3	3120 B4	3137 B4	3167 C2	4106 B4	4154 C3	6131 C3	7124 C4
6 A5	2109 A4	2126 C2	2146 C1	2159 C2	3106 C4	3121 A3	3140 B1	3168 B3	4107 C4	4155 A4	7101 B2	
7 A5	2112 B5	2127 C2	2147 C1	2160 C4	3108 A4	3122 B3	3141 C2	3169 B2	4108 B4	4156 A2	7103 C2	
	2113 A4	2131 C2	2149 B2	2161 A3	3109 A4	3123 A3	3143 C2	3175 A2	4109 A3	4157 B3	7106 A4	
	2114 A4	2132 C1	2150 B2	2163 A2	3111 A3	3125 A3	3144 C2	3176 C2	4110 A3	4158 C2	7108 A3	
	2116 B3	2134 C1	2151 C2	2165 B3	3112 A3	3126 B3	3145 C2	3177 A1	4111 C1	4159 A2	7109 A3	
	2117 A3	2136 B1	2152 C3	2166 B2	3114 A3	3127 B3	3146 A1	4101 A4	4120 C2	4160 A1	7111 A1	
	2118 B4	2139 B2	2153 C3	2167 B2	3115 A3	3128 B3	3148 A1	4102 A4	4150 B2	6105 A4	7120 B4	



TUNER BOARD ECO5 / Systems





VERSION PROGRAMMING COMPONENTS

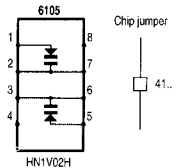
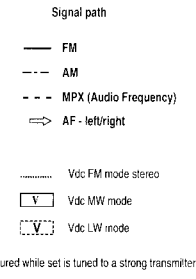
	6120	3156	3157	3170	remark
/00 FMMW/LW	x	-	-	-	7111
/00 FMMW/LW/SW-Eu	-	-	-	-	not mounted
/01 FMMW-Stereo	-	-	x	-	SW
/01 FMMW	-	x	-	-	
/01 FMMW/SW-Ov	-	x	-	-	
/05 FM-Japan/MW-stereo	-	-	-	x	
/13 FMMW-Stereo	-	-	x	-	SW
/14 FM-OIRT/MW/LW	x	-	x	x	
/17 FMMW-Stereo	-	-	x	-	SW
/17 FMMW	x	-	-	-	
/15 FMMW/2xSW	-	-	x	x	
/15 FMMW/SW-Eu	-	x	x	x	

x = component mounted
SW = Software initialisation

- 1101 A 1
- 1102 B 2
- 1103 D 2
- 1124 G 2
- 1128 E 2
- 1130 H 2
- 1131 H 2
- 2101 C 6
- 2102 G 7
- 2103 D 9
- 2104 B 9
- 2106 F 5
- 2107 G 5
- 2108 G 3
- 2109 G 3
- 2120 L 1
- 2122 N 1
- 2125 M 1
- 2125 M 1
- 2126 G 9
- 2127 G 10
- 2128 C 1
- 2129 G 9
- 2130 H 7
- 2131 I 0
- 2132 H 0
- 2133 H 1
- 2134 J 7
- 2135 J 8
- 2136 J 7
- 2137 H 6
- 2138 H 2
- 2140 H 4
- 2141 H 4
- 2142 H 4
- 2143 I 7
- 2144 H 7
- 2145 G 16
- 2146 F 15
- 2147 F 16
- 2148 F 16
- 2149 B 13
- 2150 B 13
- 2152 F 7
- 2153 E 9
- 2154 F 7
- 2155 D 6
- 2158 M 1
- 2159 F 9
- 2160 M 2
- 2161 D 16
- 2163 E 16
- 2165 C 9
- 2166 G 16
- 3101 E 7
- 3102 E 7
- 3103 C 6
- 3104 B 1
- 3105 D 6
- 3108 C 3
- 3109 F 9
- 3110 F 7
- 3123 M 7
- 3125 M 8
- 3126 M 8
- 3132 L 9
- 3134 M 12
- 3137 M 13
- 3141 G 10
- 3142 G 9
- 3145 H 10
- 3146 H 7
- 3152 H 8
- 3153 H 9
- 3154 H 8
- 3155 G 17
- 3157 F 17
- 3158 F 8
- 3159 F 8
- 3160 E 8
- 3161 E 8
- 3167 G 18
- 3169 G 15
- 3170 F 17
- 3171 H 15
- 3175 B 16
- 3177 H 6
- 4101 G 5
- 4102 F 5
- 4103 G 9
- 4104 B 13
- 4105 B 11
- 4106 K 2
- 4108 L 4
- 5102 E 4
- 5103 F 4
- 5109 B 13
- 5110 B 14
- 5111 A 13
- 5112 A 15
- 5113 B 12
- 5114 C 16
- 5120 H 13
- 5121 F 15
- 5122 M 1
- 5123 L 11
- 5130 E 8
- 5131 D 8
- 6103 C 2
- 6104 C 3
- 6105 K 12
- 6105 E 6
- 6107 H 7
- 6120 G 16
- 6130 E 7
- 6131 D 7
- 7101 G 11
- 7102 D 8
- 7104 E 3
- 7105 H 2
- 7109 M 7
- 7111 F 8
- 7122 M 8
- 7124 M 3
- 9103 B 4
- 9101 D 6
- 9117 L 10
- 9126 A 4

RTV servis Horvat
 Kešinci, 31402 Semeljci
 031-856-139
 031-856-637
 098-788-319
rtv-servis-horvat@os.tel.hr
 Croatia

t...for Japanese version (/06/26) only
 u...for 2-band (FM/AM) version only
 v...for SW-version 3.9-12.1MHz only
 w...for LW only
 x...not for all versions
 y...for USA version (/17/37) only
 z...for AM-STEREO (/06/13/26/33) version only



ELECTRICAL PARTSLIST TUNER ECO5 BOARD**ELECTRICAL PA****MISCELLANEOUS**

1101 4822 267 31505 SOCKET 2P CLICKFIT

DIODES

6103 4822 130 30621 1N4148
 6104 4822 130 30621 1N4148
 6105 4822 130 83075 HN1V02H
 6107 4822 130 34488 BZX79-C11
 6120 4822 130 30621 1N4148

6130 4822 130 82833 1SV228
 6131 4822 130 82833 1SV228

TRANSISTORS

7102 4822 130 60093 2SA838B
 7111 5322 130 42136 BC848C(CHIP)

INTEGRATED CIRCUITS

7101 4822 209 90924 TEA5757H/V1,RADIO IC

COILS

5102 4822 157 71634 RF-COIL MW
 5109 4822 242 70665 CER. FILTER 10,7MHZ
 5110 4822 242 70665 CER. FILTER 10,7MHZ
 5111 4822 158 60511 AM-IF FILTER 450kHz
 5112 4822 157 70302 AM-IF FILTER 450kHz
 5114 4822 157 71637 AM-AFC FILTER 450KHZ
 5120 4822 242 82065 CER. DISCRIMINATOR
 5121 4822 242 81021 QUARTZ 75kHz
 5123 4822 157 60517 110µH 8%
 5130 4822 156 30947 RF COIL 1,5 TURNS

5131 4822 156 30947 RF COIL 1,5 TURNS

RESISTORS

3105 4822 116 52215 220R 5% 0,16W
 3110 4822 116 52195 47R 5% 0,5W
 3132 4822 116 52195 47R 5% 0,5W
 3142 4822 100 11163 TRIMPOT.100k lin.
 3152 4822 116 52224 470R 5% 0,5W
 3154 4822 116 52211 150R 5% 0,5W
 3158 4822 116 52224 470R 5% 0,5W
 3159 4822 116 52224 470R 5% 0,5W
 3160 4822 116 52224 470R 5% 0,5W
 3161 4822 116 52224 470R 5% 0,5W

3170 4822 116 52234 100k 5% 0,5W
 3171 4822 116 52219 330R 5% 0,5W

CHIP RESISTORS

3101 4822 051 20562 5k6 5% 0,1W
 3102 4822 051 20104 100k 5% 0,1W
 3103 4822 051 20183 18k 5% 0,1W
 3104 4822 051 20181 180R 5% 0,1W
 3134 4822 051 20224 220k 5% 0,1W
 3140 4822 051 20008 CHIP JUMPER 0805
 3141 4822 051 20563 56k 5% 0,1W
 3145 4822 051 20222 2k2 5% 0,1W
 3146 4822 051 20229 22R 5% 0,1W
 3153 4822 051 20471 470R 5% 0,1W
 3155 4822 051 20471 470R 5% 0,1W
 3167 4822 051 20221 220R 5% 0,1W

CHIP RESISTORS

3169 4822 051 20154 150k 5% 0,1W
 4101 4822 051 20008 CHIP JUMPER 0805
 4102 4822 051 20008 CHIP JUMPER 0805
 4103 4822 051 20008 CHIP JUMPER 0805
 4104 4822 051 20008 CHIP JUMPER 0805
 4105 4822 051 20008 CHIP JUMPER 0805
 4106 4822 051 20008 CHIP JUMPER 0805
 4108 4822 051 20008 CHIP JUMPER 0805
 4111 4822 051 20008 CHIP JUMPER 0805
 4120 4822 051 20008 CHIP JUMPER 0805
 4150 4822 051 10008 CHIP JUMPER1206
 4152 4822 051 10008 CHIP JUMPER1206
 4153 4822 051 10008 CHIP JUMPER1206
 4154 4822 051 10008 CHIP JUMPER1206
 4157 4822 051 10008 CHIP JUMPER1206
 4158 4822 051 10008 CHIP JUMPER1206
 4159 4822 051 10008 CHIP JUMPER1206

CAPACITORS

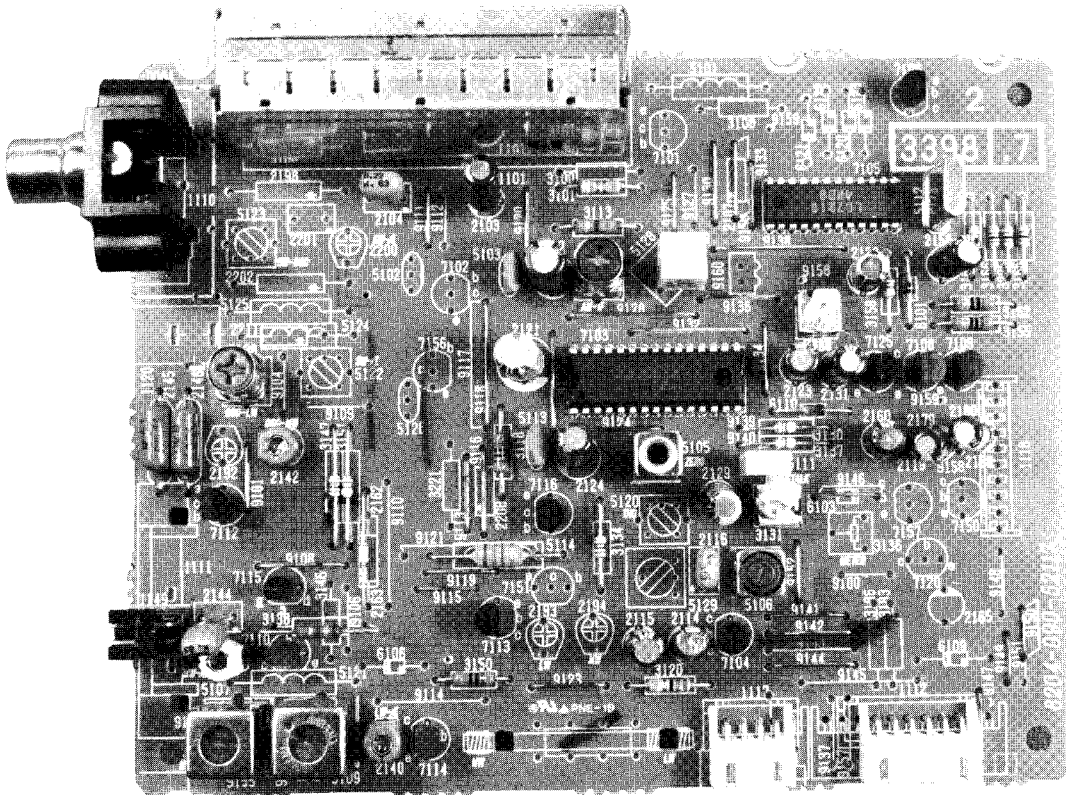
2104 4822 122 33195 100pF 10% 50V
 2106 4822 125 60101 10pF VARIABLE
 2107 4822 121 51252 470nF 5% 63V
 2125 4822 121 51381 560pF 1% 400V
 2128 4822 124 41579 10µF 20% 50V
 2129 4822 124 41584 100µF 20% 10V
 2130 4822 126 11585 22nF+80/-20% 50V
 2133 4822 124 40242 1µF 20% 63V
 2135 4822 124 40746 0,22µF 20% 63V
 2137 4822 124 40746 0,22µF 20% 63V
 2138 4822 124 41576 2,2µF 20% 50V
 2140 4822 121 51252 470nF 5% 63V
 2144 4822 124 40242 1µF 20% 63V
 2148 4822 126 11585 22nF+80/-20% 50V
 2155 4822 125 60101 10pF VARIABLE

CHIP CAPACITORS

2101 5322 122 32531 100pF 5% 50V
 2102 4822 122 33177 10nF 20% 50V
 2103 5322 122 34123 1nF 10% 50V
 2120 5322 122 32658 22pF 5% 50V
 2126 5322 122 31863 330pF 5% 50V
 2127 4822 122 32927 220nF 10% 63V
 2131 4822 122 33325 470nF 20% 50V
 2132 4822 122 33325 470nF 20% 50V
 2134 5322 122 32654 22nF 10% 63V
 2136 5322 122 32654 22nF 10% 63V
 2141 4822 122 31947 100nF 20% 50V
 2142 4822 122 31947 100nF 20% 50V
 2143 4822 122 32927 220nF 10% 63V
 2145 4822 122 33575 220pF 5% 50V
 2146 4822 122 33575 220pF 5% 50V
 2147 4822 122 33575 220pF 5% 50V
 2149 5322 122 32654 22nF 10% 63V
 2150 4822 122 31947 100nF 20% 50V
 2152 5322 116 80853 560pF 5% 63V
 2153 4822 122 32139 12pF 5% 63V
 2159 5322 122 32659 33pF 5% 50V
 2160 5322 122 32654 22nF 10% 63V
 2165 4822 122 31947 100nF 20% 50V
 2166 5322 122 34123 1nF 10% 50V

CHIP CAPACITORS

2167 4822 122



TUNER 94 BOARD

TABLE OF CONTENTS

Blockdiagram	7C-1
Adjustmant table	7C-2
Component layout.....	7C-2
Circuit diagram.....	7C-3
Partslist	7C-4

RTV servis Horvat

Kešinci, 31402 Semeljci

031-856-139

031-856-637

098-788-319

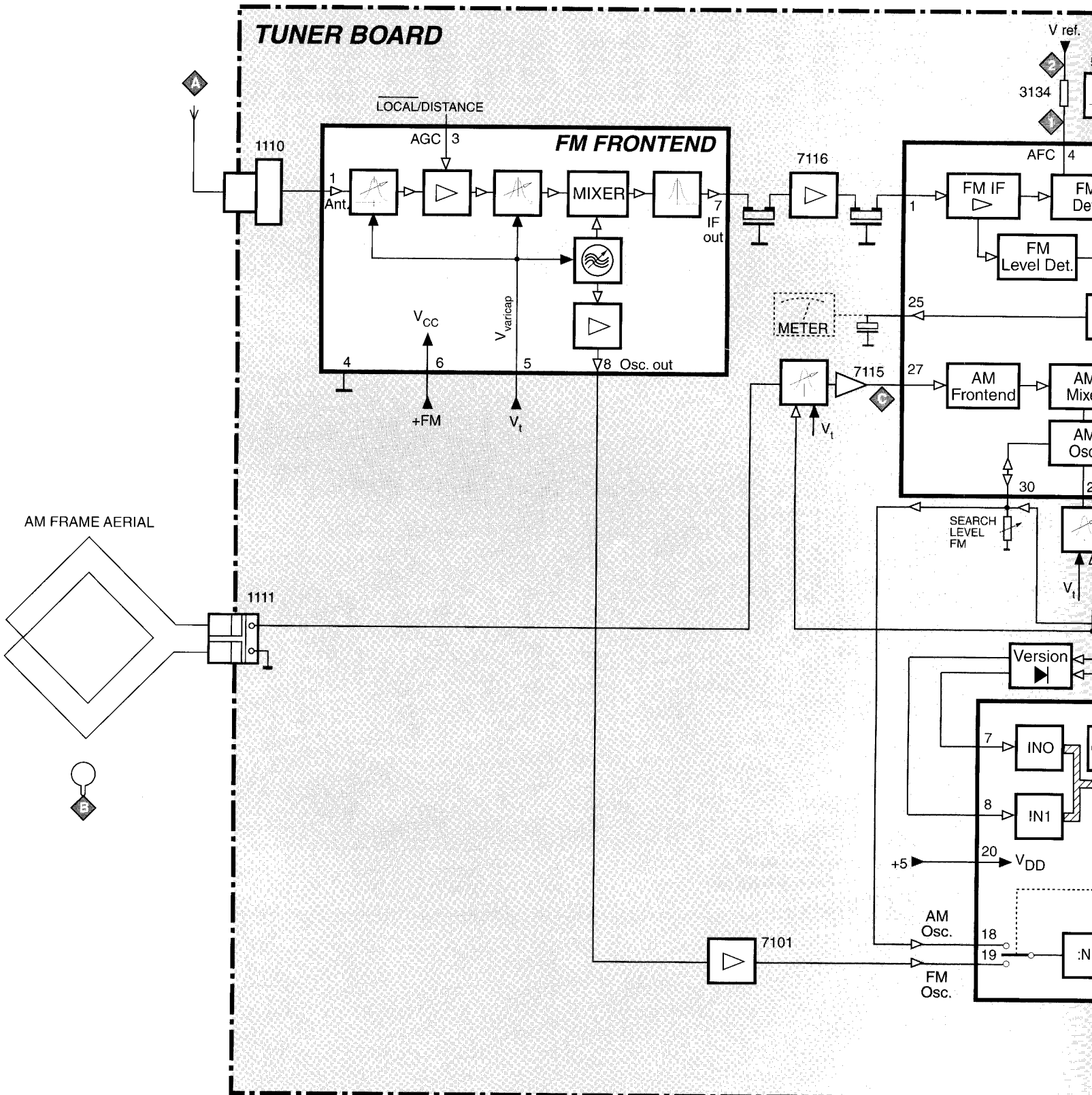
rtv-servis-horvat@os.tel.hr

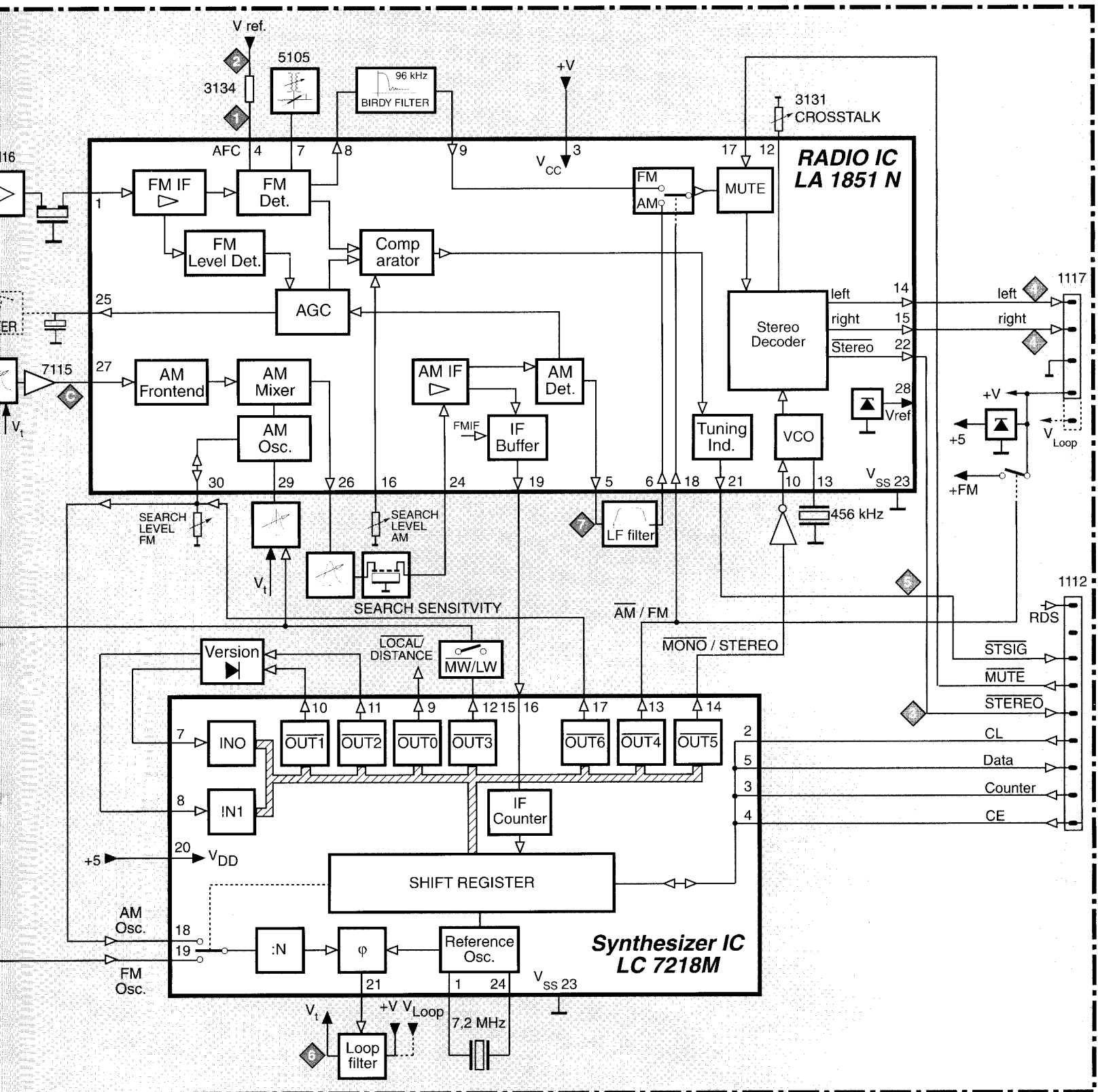
Croatia

AM FRAM

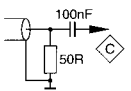


BLOCKDIAGRAM





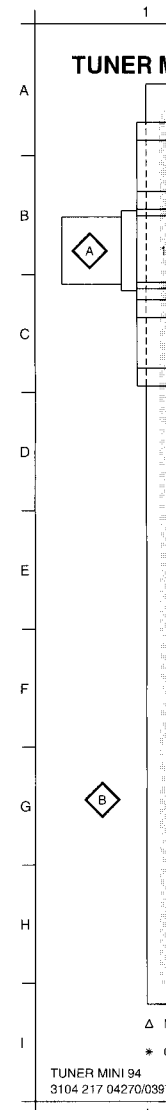
ADJUSTMENT TABLE

Waverange	Input frequency	Input	Tuned to	Adjust	Output	Scope/Voltmeter
<i>VARICAP ALIGNMENT</i>						
FM 87.5 - 108MHz (50kHz grid)			108MHz	check	◇6	7...9V
			87.5MHz	check		1.3...2V
LW 153 - 279kHz (3kHz grid)			279kHz	5108		8.5V ±0.1V
			153kHz	check		0.7...1.5V
MW 522 - 1611kHz (9kHz grid)			1611kHz	2142		8V ±0.1V
			522kHz	check		0.7...1.7V
<i>FM IF</i>						
FM	98MHz 1mV mod=1kHz Δf=75kHz	◇A	98MHz	5105	◇1 ◇2	0V ±20mV
<i>STEREO CROSSTALK</i>						
FM	98MHz 1mV 90% L + 9% pilot	◇A	98MHz	check	◇3	low < 1V
				3131	◇4	right channel min.
<i>SEARCH SENSITIVITY</i>						
FM	98MHz 12μV mod=1kHz Δf=75kHz	◇A		3125	◇5	switches just from high to low
<i>AM IF</i>						
MW	1494kHz Δf=10kHz as low as possible			5104	◇7	symmetrical and max. height
<i>AM RF</i>						
LW	155kHz mod=1kHz, 30% AM 270kHz	◇B*	155kHz	5109	◇7	MAX
			270kHz	2140		
MW	558kHz mod=1kHz, 30% AM 1494kHz		558kHz	5107		MAX
			1494kHz	2141		

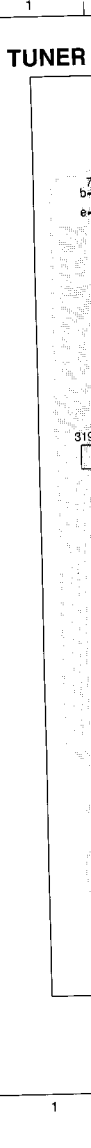
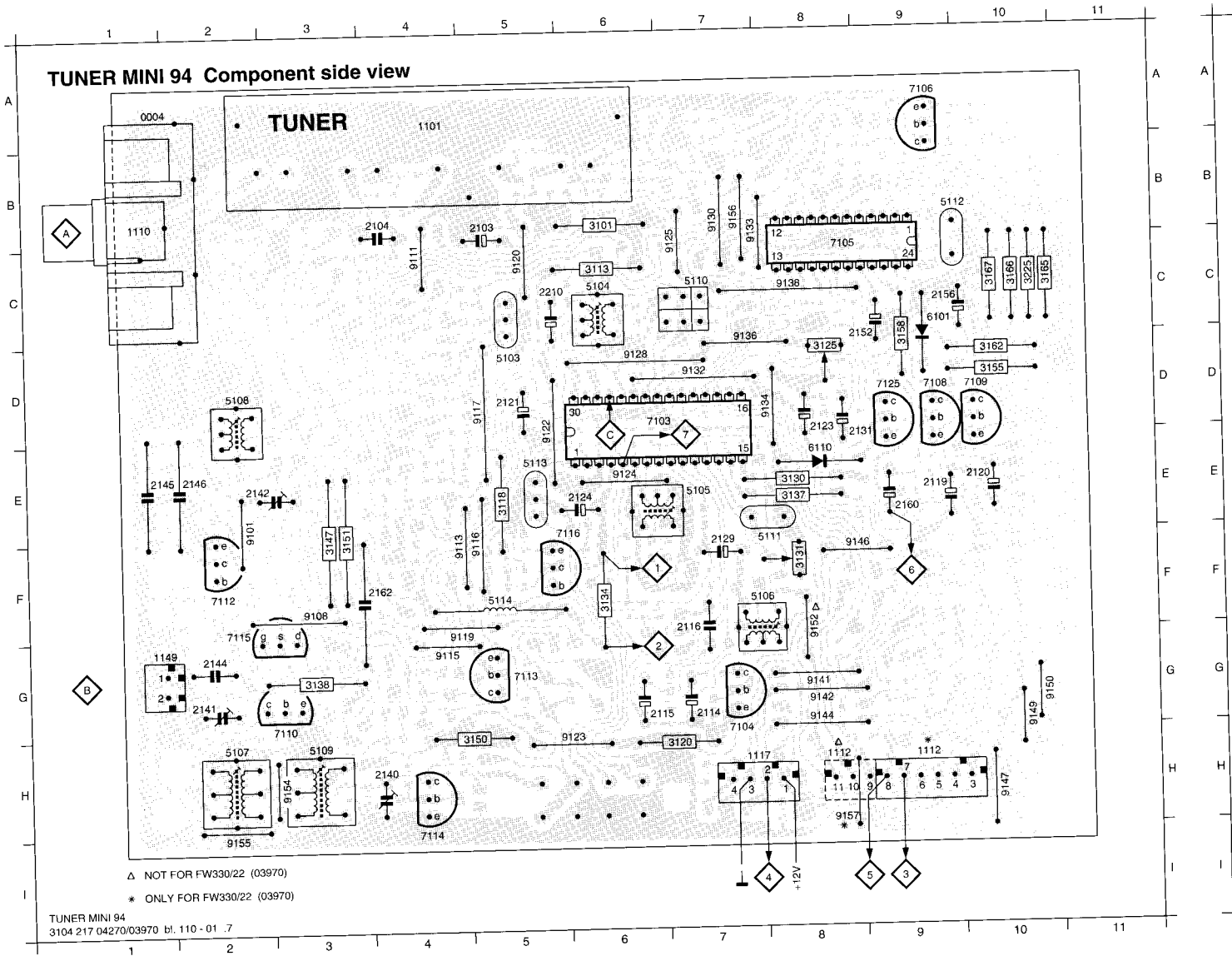
* Signal supplied via frame antenna

↑ Repeat

0004 A1 21
1101 A4 21
1110 B1 21
1112 H8 21
1112 H9 21
1117 H7 21
1149 G1 21
2103 B5 21
2104 B4 21
2114 G7 21

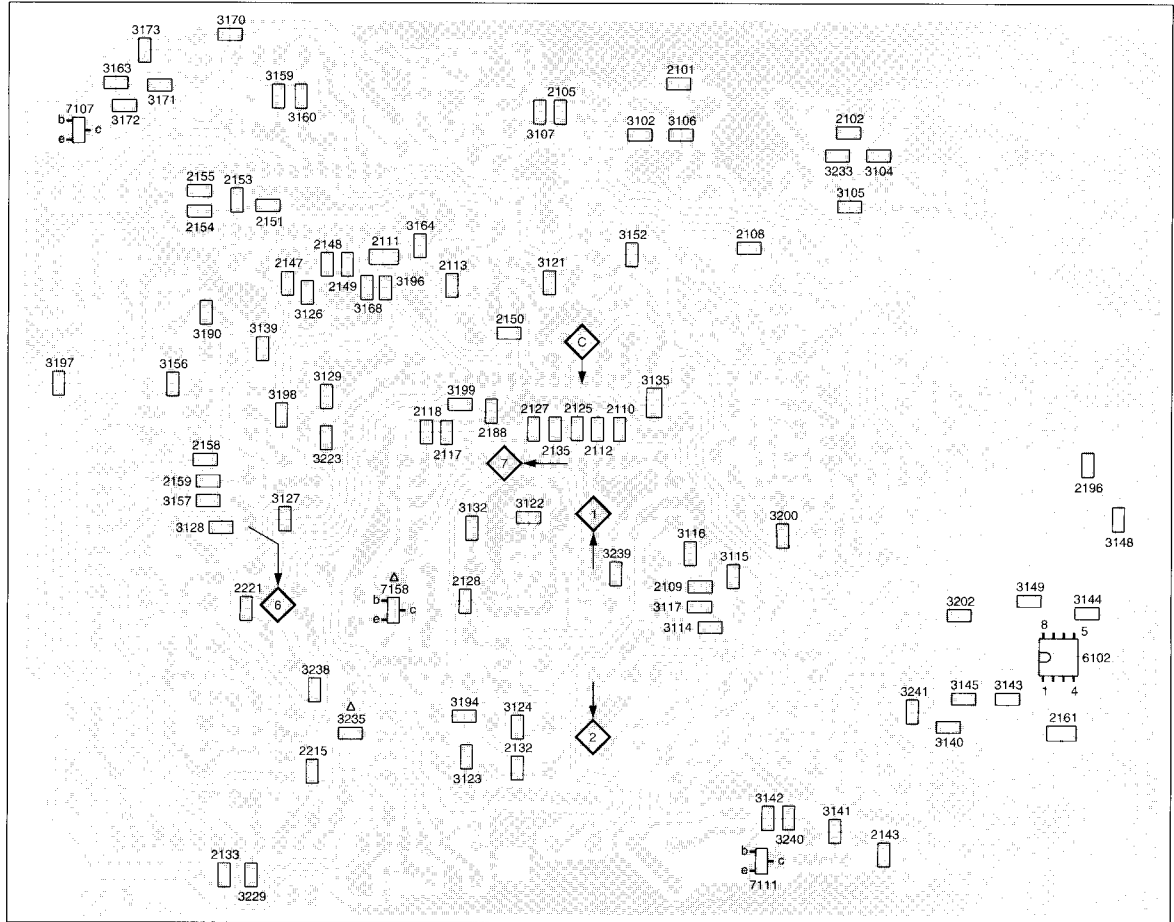


0004	A1	2115	G6	2141	G2	3101	B6	3147	F3	5103	D5	5113	E5	7110	G3	9113	F4	9128	D6	2101	A7	2
1101	A4	2116	F7	2142	E2	3113	C6	3150	H4	5104	C6	5114	F5	7112	F2	9115	G4	9130	B7	2102	B8	2
1110	B1	2119	E9	2144	G2	3118	E5	3151	F3	5105	E7	6101	C9	7113	G5	9116	F5	9132	D7	2105	B6	2
1112	H8	2120	E10	2145	E1	3120	H7	3155	D10	5106	F7	6110	E8	7114	I4	9117	D5	9133	C7	2108	C7	2
1112	H9	2121	D5	2146	E2	3125	D8	3158	D9	5107	H2	7103	D6	7115	F2	9119	G4	9134	D8	2109	F6	2
1117	H7	2123	D8	2152	D8	3130	E8	3162	D10	5108	D2	7104	H7	7116	F5	9120	C5	9136	D7	2110	D6	2
1149	G1	2124	E6	2156	C9	3131	F8	3165	C10	5109	H3	7105	C8	7125	D9	9122	E5	9138	C8	2111	C4	2
2103	B5	2129	F7	2160	E9	3134	F6	3166	C10	5110	C7	7106	A9	9101	F2	9123	H5	9141	G8	2112	E6	2
2104	B4	2131	E8	2162	F3	3137	E8	3167	C10	5111	F7	7108	D9	9108	F3	9124	E6	9142	G8	2113	C5	2
2114	G7	2140	H4	2210	C5	3138	G3	3225	C10	5112	B9	7109	D10	9111	C4	9125	C7	9144	G8	2117	E5	2



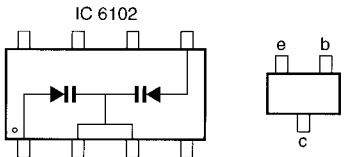
F4	9128	D6	2101	A7	2118	D4	2149	C4	2196	E10	3116	E7	3132	E5	3149	F10	3171	B2	3202	F9	7107	B1
G4	9130	B7	2102	B8	2125	D6	2150	D5	2215	G3	3117	F6	3135	D6	3152	C6	3172	B2	3223	E4	7111	H7
F5	9132	D7	2105	B6	2127	D5	2151	C3	2221	F3	3121	C5	3139	D3	3156	D2	3173	A2	3229	H3	7158	F4
D5	9133	C7	2108	C7	2128	F5	2153	B3	3102	B6	3122	E5	3140	G9	3157	E2	3190	D3	3233	B8		
G4	9134	D8	2109	F6	2132	G5	2154	C2	3104	B8	3123	H5	3141	H8	3159	B3	3194	G5	3235	G4		
C5	9136	D7	2110	D6	2133	H3	2155	B2	3105	C8	3124	G5	3142	H7	3160	B3	3196	C4	3238	G3		
E5	9138	C8	2111	C4	2135	E5	2158	E3	3106	B7	3126	D3	3143	G9	3163	A2	3197	D1	3239	F6		
H5	9141	G8	2112	E6	2143	H8	2159	E2	3107	B5	3127	E3	3144	F10	3164	C4	3198	D3	3240	H7		
E6	9142	G8	2113	C5	2147	C3	2161	G10	3114	F7	3128	E2	3145	G9	3168	D4	3199	D5	3241	G9		
C7	9144	G8	2117	E5	2148	C4	2188	E5	3115	F7	3129	D4	3148	E10	3170	A3	3200	E7	6102	F10		

TUNER MINI 94 Copper side view

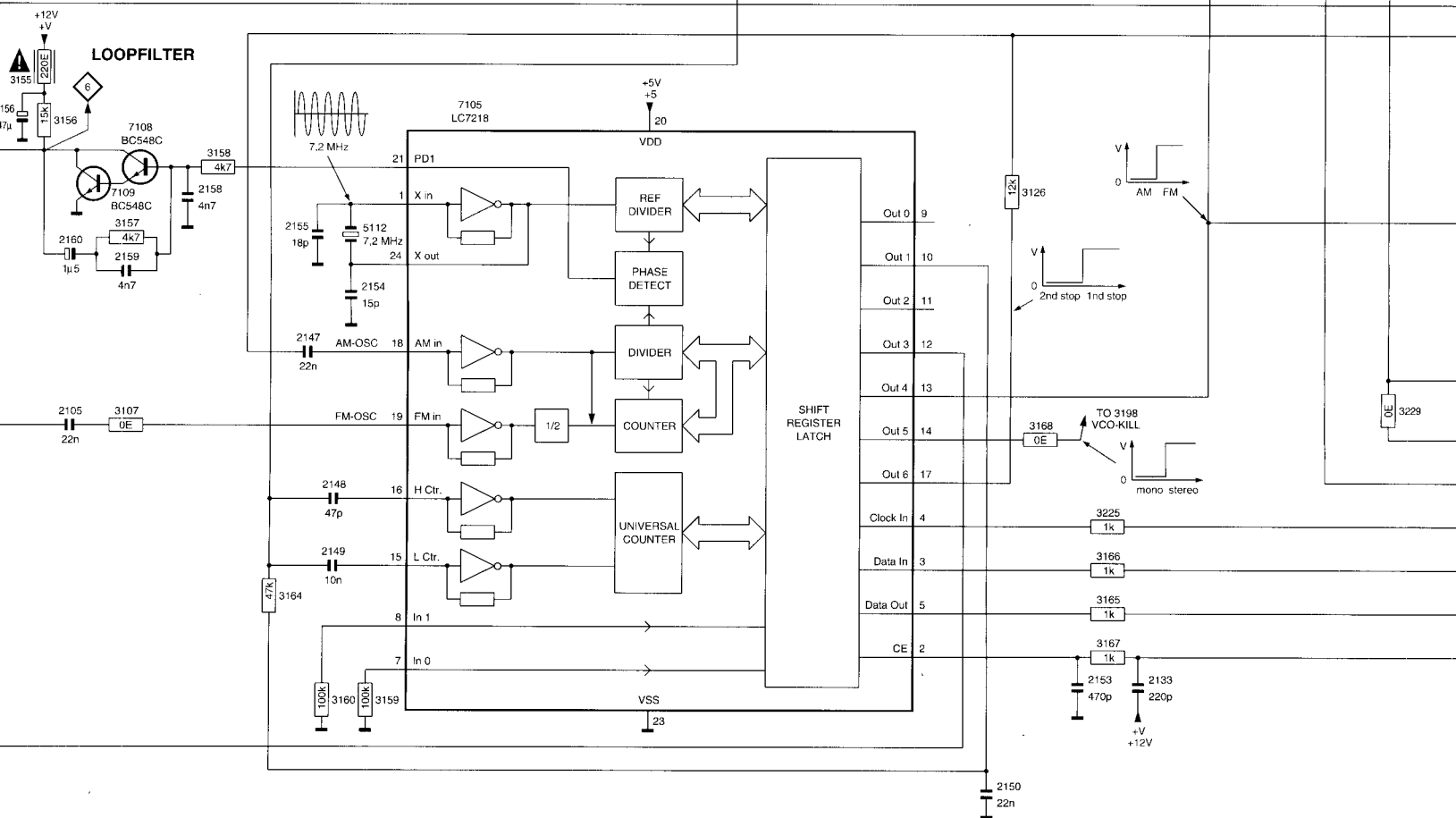
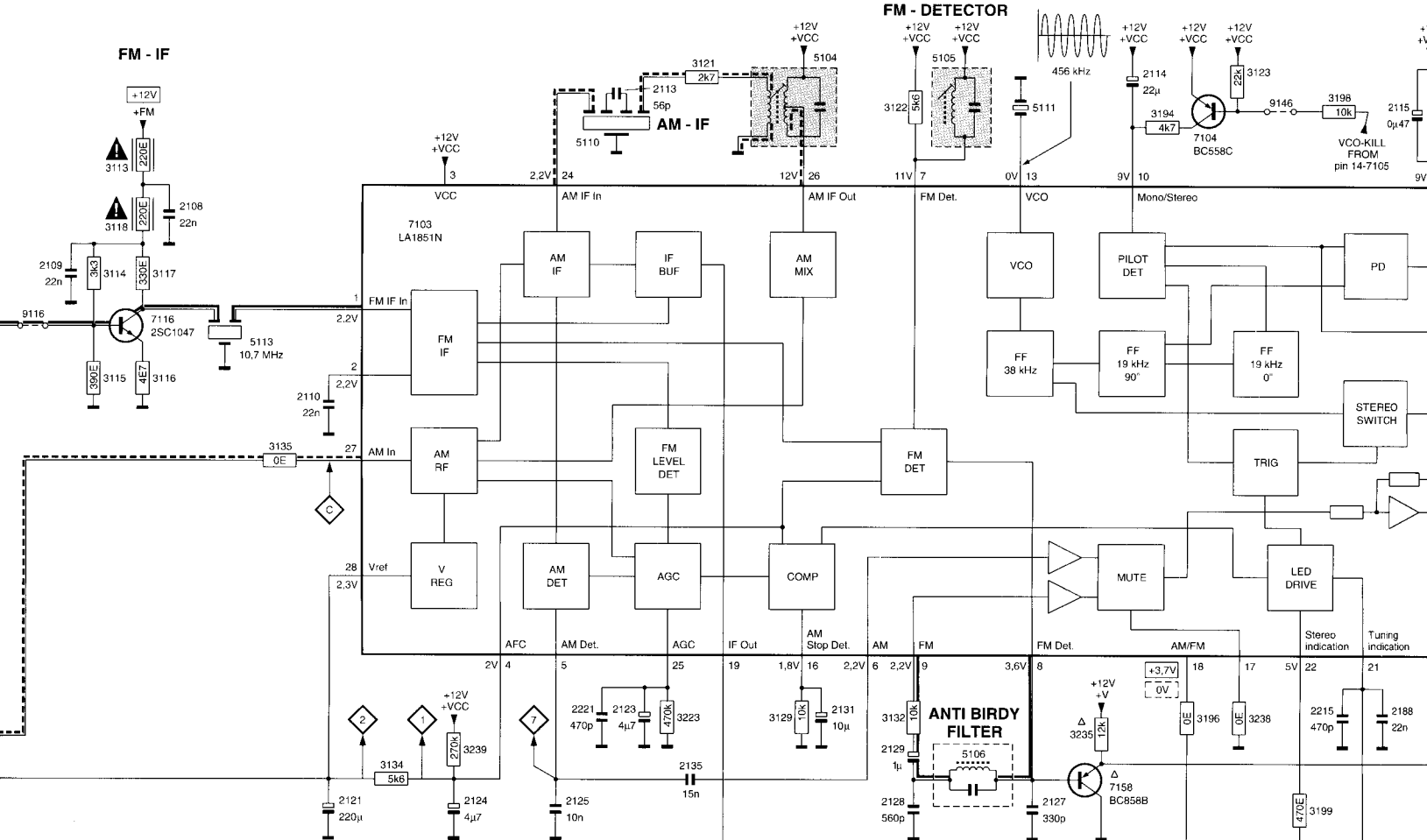


△ NOT FOR FW330/22 (03970)
 * ONLY FOR FW330/22 (03970)

LEU0116
 9504



10 11 12 13 14 15 16 17 18 19 20 21 22



10 11 12 13 14 15 16 17 18 19 20 21 22

RTV servis Horvat

Kešinci, 31402 Semeljci

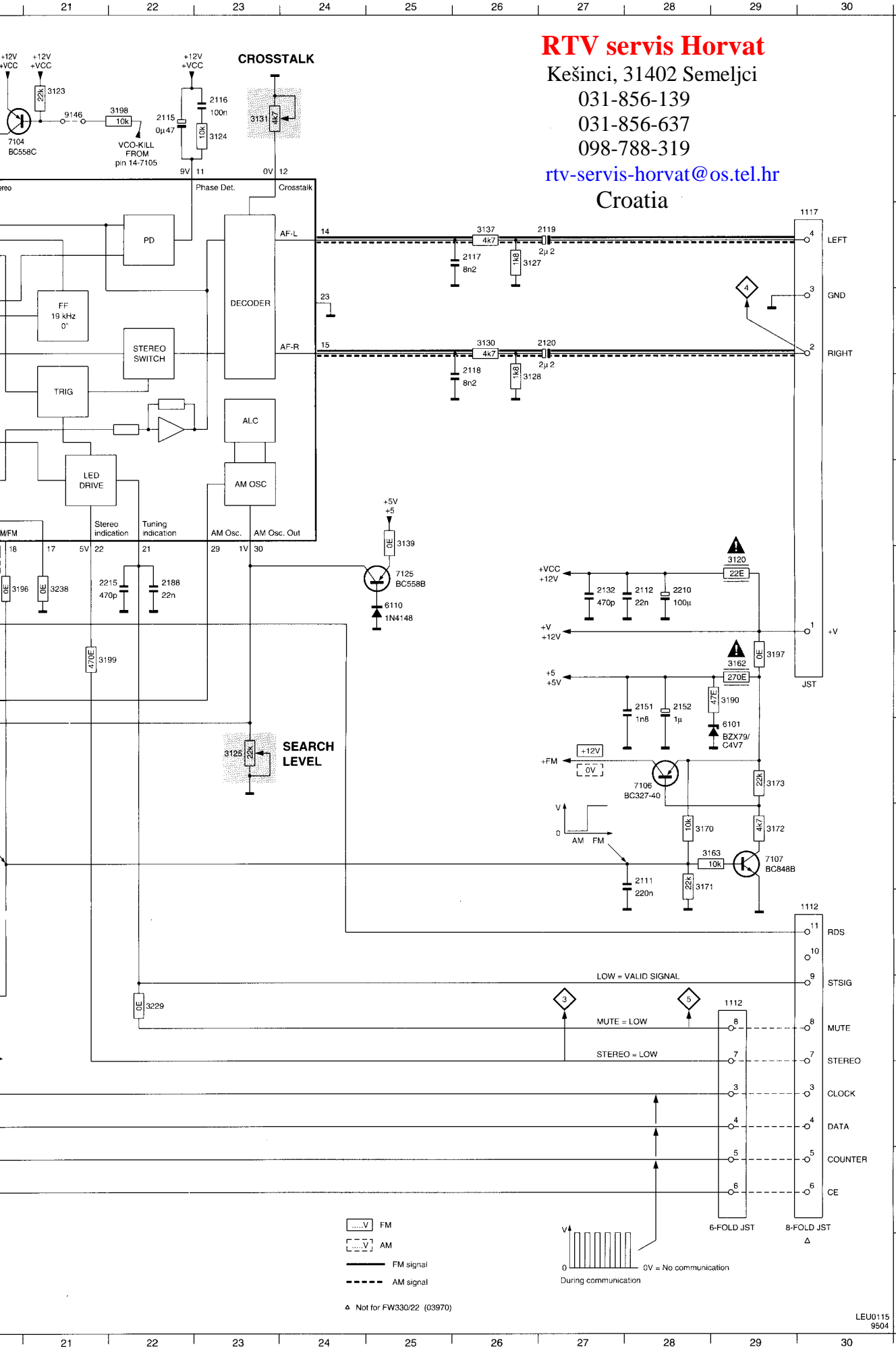
031-856-139

031-856-637

098-788-319

rtv-servis-horvat@os.tel.hr

Croatia



1101	B6	3196	G20
1110	C1	3197	H29
1112	L29	3198	A22
1112	K30	3199	H21
1117	C30	3200	C9
1149	J2	3202	I9
2101	B3	3223	G16
2102	B4	3225	M19
2103	B2	3229	L22
2104	E8	3233	E7
2105	L10	3235	G19
2108	B11	3238	G21
2109	C10	3239	G14
2110	D12	3240	N3
2111	J28	3241	N2
2112	G28	5103	D8
2113	A15	5104	A17
2114	A20	5105	A18
2115	B22	5106	G18
2116	A23	5107	K5
2117	C26	5108	K8
2118	D26	5109	N5
2119	C26	5110	B15
2120	D26	5111	B19
2121	H13	5112	J13
2123	G15	5113	D12
2124	H14	5114	J8
2125	H15	6101	I29
2127	H19	6102	K6
2128	H18	6110	G25
2129	G18	7103	C13
2131	G17	7104	B20
2132	G27	7105	I14
2133	N20	7106	I28
2135	G16	7107	J29
2140	N4	7108	I11
2141	L6	7109	J11
2142	N9	7110	M4
2143	N5	7111	N3
2144	L7	7112	M8
2145	K9	7113	O7
2146	M8	7114	N3
2147	K12	7115	J5
2148	M12	7116	C11
2149	M12	7125	G25
2150	O18	7158	H20
2151	H28	9116	C10
2152	H28	9117	C8
2153	N19	9146	B21
2154	K13		
2155	J12		
2156	I10		
2158	J11		
2159	K11		
2160	J10		
2161	J6		
2162	J7		
2188	G22		
2196	M8		
2210	G28		
2215	G21		
2221	G15		
3101	A2		
3102	A3		
3104	B4		
3105	E8		
3106	C7		
3107	L11		
3113	B11		
3114	C11		
3115	D11		
3116	D11		
3117	C11		
3118	C11		
3120	G29		
3121	A16		
3122	B18		
3123	A21		
3124	B23		
3125	I23		
3126	J19		
3127	C26		
3128	E26		
3129	G17		
3130	D26		
3131	B23		
3132	G18		
3134	G13		
3135	E12		
3137	C26		
3138	J6		
3139	G25		
3140	M2		
3141	N3		
3142	N2		
3143	K6		
3144	K6		
3145	J6		
3147	K7		
3148	L7		
3149	N7		
3150	N7		
3151	O7		
3152	O8		
3155	I10		
3156	I10		
3157	J11		
3158	J11		
3159	N13		
3160	N13		
3162	H29		
3163	J28		
3164	N12		
3165	N19		
3166	M19		
3167	N19		
3168	L19		
3170	J28		
3171	K28		
3172	J29		
3173	I29		
3190	H29		
3194	B20		

ELECTRICAL PARTSLIST TUNER 94 BOARD**ELECTRICAL****MISCELLANEOUS**

1101	4822 210 10492	FRONTEND ASSY /02/08
1110	4822 267 10283	SOCKET COAX IEC 75R

DIODES

6101	4822 130 34174	BZX79-B4V7
6102	4822 130 83075	HN1V02H
6110	4822 130 30621	1N4148

TRANSISTORS

7104	5322 130 60068	BC558C
7106	4822 130 41327	BC327-40
7107	5322 130 41982	BC848 (CHIP)
7108	4822 130 44196	BC548C
7109	4822 130 44196	BC548C
7110	5322 130 44779	BC338-40
7111	5322 130 41982	BC848 (CHIP)
7112	4822 130 60163	2SC1047
7113	4822 130 44196	BC548C
7114	5322 130 44779	BC338-40
7115	4822 130 41024	BF245B
7116	4822 130 60163	2SC1047
7125	4822 130 44197	BC558B
7158	5322 130 41983	BC858B(CHIP)

INTEGRATED CIRCUITS

7103	4822 209 31001	LA1851N
7105	4822 209 30178	LC7218

COILS

5103	4822 242 81249	CER. FILTER 10,7MHz
5104	4822 157 63029	AM IF COIL
5105	4822 157 63904	Q-DETECION COIL
5106	4822 157 71661	ANTI-BIRDY FILTER
5107	4822 157 71094	ANT. COIL MW, 3-BAND
5108	4822 157 63912	OSC.COIL AM 3-BAND
5109	4822 157 71093	ANT. COIL LW
5110	4822 242 71878	CERAM.FILTER 450kHz
5111	4822 242 81248	CERAM. RES. 19kHz
5112	4822 242 72976	CER.RESONATOR 7,2MHz
5113	4822 242 81249	CER. FILTER 10,7MHz
5114	4822 157 51503	560µH

RESISTORS

3101	4822 052 10478	4R7	5%	NFR
3113	4822 053 10221	220R	5%	1W
3118	4822 050 22201	220R	2%	0,25W
3120	4822 052 10229	22R	5%	0,33W
3125	4822 100 11213	22k	30%	POT.
3130	4822 116 52283	4k7	5%	0,5W
3131	4822 100 11319	4k7		trimpot.
3134	4822 116 52289	5k6	5%	0,16W
3137	4822 116 52283	4k7	5%	0,5W
3138	4822 116 83922	150R	5%	1W
3147	4822 116 52289	5k6	5%	0,16W
3150	4822 050 25601	560R	1%	0,6W
3151	4822 116 52283	4k7	5%	0,5W
3155	4822 050 22201	220R	2%	0,25W
3158	4822 116 52283	4k7	5%	0,5W

RESISTORS

3162	4822 050 22701	270R	1%	0,6W
3165	4822 050 11002	1k	5%	0,2W
3166	4822 050 11002	1k	5%	0,2W
3167	4822 050 11002	1k	5%	0,2W
3225	4822 050 11002	1k	5%	0,2W

CHIP RESISTORS

3102	4822 051 20224	220k	5%	0,1W
3104	4822 051 20154	150k	5%	0,1W
3105	4822 051 20562	5k6	5%	0,1W
3106	4822 051 20829	82R	5%	0,1W
3107	4822 051 20008	CHIP JUMPER 0805		
3114	4822 051 20332	3k3	5%	0,1W
3115	4822 051 20391	390R	5%	0,1W
3116	4822 051 20478	4R7	5%	0,1W
3117	4822 051 20331	330R	5%	0,1W
3121	4822 051 20272	2k7	5%	0,1W
3122	4822 051 20562	5k6	5%	0,1W
3123	4822 051 20223	22k	5%	0,1W
3124	4822 117 10833	10k	1%	0,1W
3126	4822 051 20123	12k	2%	0,1W
3127	4822 051 20182	1k8	5%	0,1W
3128	4822 051 20182	1k8	5%	0,1W
3129	4822 117 10833	10k	1%	0,1W
3132	4822 117 10833	10k	1%	0,1W
3133	4822 051 20008	CHIP JUMPER 0805		
3135	4822 051 10008	CHIP JUMPER1206		

3139	4822 051 20008	CHIP JUMPER 0805		
3140	4822 051 20821	820R	5%	0,1W
3141	4822 051 20182	1k8	5%	0,1W
3142	4822 051 20472	4k7	5%	0,1W
3143	4822 051 20821	820R	5%	0,1W
3144	4822 051 20331	330R	5%	0,1W
3145	4822 051 20271	270R	5%	0,1W
3148	4822 051 20104	100k	5%	0,1W
3149	4822 051 20472	4k7	5%	0,1W
3152	4822 117 10833	10k	1%	0,1W

3156	4822 051 20153	15k	5%	0,1W
3157	4822 051 20472	4k7	5%	0,1W
3159	4822 051 20104	100k	5%	0,1W
3160	4822 051 20104	100k	5%	0,1W
3163	4822 117 10833	10k	1%	0,1W

3164	4822 051 10473	47k	2%	0,25W
3164	4822 051 20473	47k	5%	0,1W
3168	4822 051 20008	CHIP JUMPER 0805		
3170	4822 117 10833	10k	1%	0,1W
3171	4822 051 20223	22k	5%	0,1W

3172	4822 051 20472	4k7	5%	0,1W
3173	4822 051 20223	22k	5%	0,1W
3190	4822 051 20479	47R	5%	0,1W
3194	4822 051 20472	4k7	5%	0,1W
3196	4822 051 20008	CHIP JUMPER 0805		

3197	4822 051 20008	CHIP JUMPER 0805		
3198	4822 117 10833	10k	1%	0,1W
3199	4822 051 20471	470R	5%	0,1W
3200	4822 051 20008	CHIP JUMPER 0805		
3202	4822 051 20008	CHIP JUMPER 0805		

3223	4822 051 20474	470k	5%	0,1W
3229	4822 051 20008	CHIP JUMPER 0805		
3233	4822 051 10102	1k	2%	0,25W
3235	4822 051 20123	12k	2%	0,1W

CHIP RESIST

3236	4822 051 20102	1k	2%	0,25W
3238	4822 051 20102	1k	2%	0,25W
3239	4822 051 20102	1k	2%	0,25W
3240	4822 051 20102	1k	2%	0,25W
3241	4822 051 20102	1k	2%	0,25W

CAPACITORS

2103	4822 051 20102	1k	2%	0,25W
2104	4822 051 20102	1k	2%	0,25W
2114	5322 051 20102	1k	2%	0,25W
2115	4822 051 20102	1k	2%	0,25W
2116	5322 051 20102	1k	2%	0,25W
2119	4822 051 20102	1k	2%	0,25W
2120	4822 051 20102	1k	2%	0,25W
2121	4822 051 20102	1k	2%	0,25W
2123	4822 051 20102	1k	2%	0,25W
2124	4822 051 20102	1k	2%	0,25W
2129	4822 051 20102	1k	2%	0,25W
2131	4822 051 20102	1k	2%	0,25W
2140	4822 051 20102	1k	2%	0,25W
2141	4822 051 20102	1k	2%	0,25W
2142	4822 051 20102	1k	2%	0,25W
2144	4822 051 20102	1k	2%	0,25W
2145	4822 051 20102	1k	2%	0,25W
2146	4822 051 20102	1k	2%	0,25W
2152	4822 051 20102	1k	2%	0,25W
2156	4822 051 20102	1k	2%	0,25W

2160	4822 051 20102	1k	2%	0,25W
2162	4822 051 20102	1k	2%	0,25W
2210	4822 051 20102	1k	2%	0,25W

CHIP CAPAC

2101	5322 051 20102	1k	2%	0,25W
2102	5322 051 20102	1k	2%	0,25W
2105	5322 051 20102	1k	2%	0,25W
2108	5322 051 20102	1k	2%	0,25W
2109	5322 051 20102	1k	2%	0,25W

2110	5322 051 20102	1k	2%	0,25W
2111	4822 051 20102	1k	2%	0,25W
2112	5322 051 20102	1k	2%	0,25W
2113	5322 051 20102	1k	2%	0,25W
2117	4822 051 20102	1k	2%	0,25W

2118	4822 051 20102	1k	2%	0,25W
2125	4822 051 20102	1k	2%	0,25W
2126	4822 051 20102	1k	2%	0,25W
2127	5322 051 20102	1k	2%	0,25W
2128	5322 051 20102	1k	2%	0,25W

2132	5322 051 20102	1k	2%	0,25W
2133	5322 051 20102	1k	2%	0,25W
2135	4822 051 20102	1k	2%	0,25W
2143	5322 051 20102	1k	2%	0,25W
2147	5322 051 20102	1k	2%	0,25W

2148	5322 051 20102	1k	2%	0,25W
2149	4822 051 20102	1k	2%	0,25W
2150	5322 051 20102	1k	2%	0,25W
2151	5322 051 20102	1k	2%	0,25W
2151	4822 051 20102	1k	2%	0,25W

2153	5322 051 20102	1k	2%	0,25W
2154	5322 051 20102	1k	2%	0,25W
2155	5322 051 20102	1k	2%	0,25W
2158	5322 051 20102	1k	2%	0,25W
2159	5322 051 20102	1k	2%	0,25W

ELECTRICAL PARTSLIST TUNER 94 BOARD

CHIP RESISTORS

3236	4822 051 20008	CHIP JUMPER 0805
3238	4822 051 20008	CHIP JUMPER 0805
3239	4822 051 20274	270k 5% 0,1W
3240	4822 051 20182	1k8 5% 0,1W
3241	4822 051 20008	CHIP JUMPER 0805

CAPACITORS

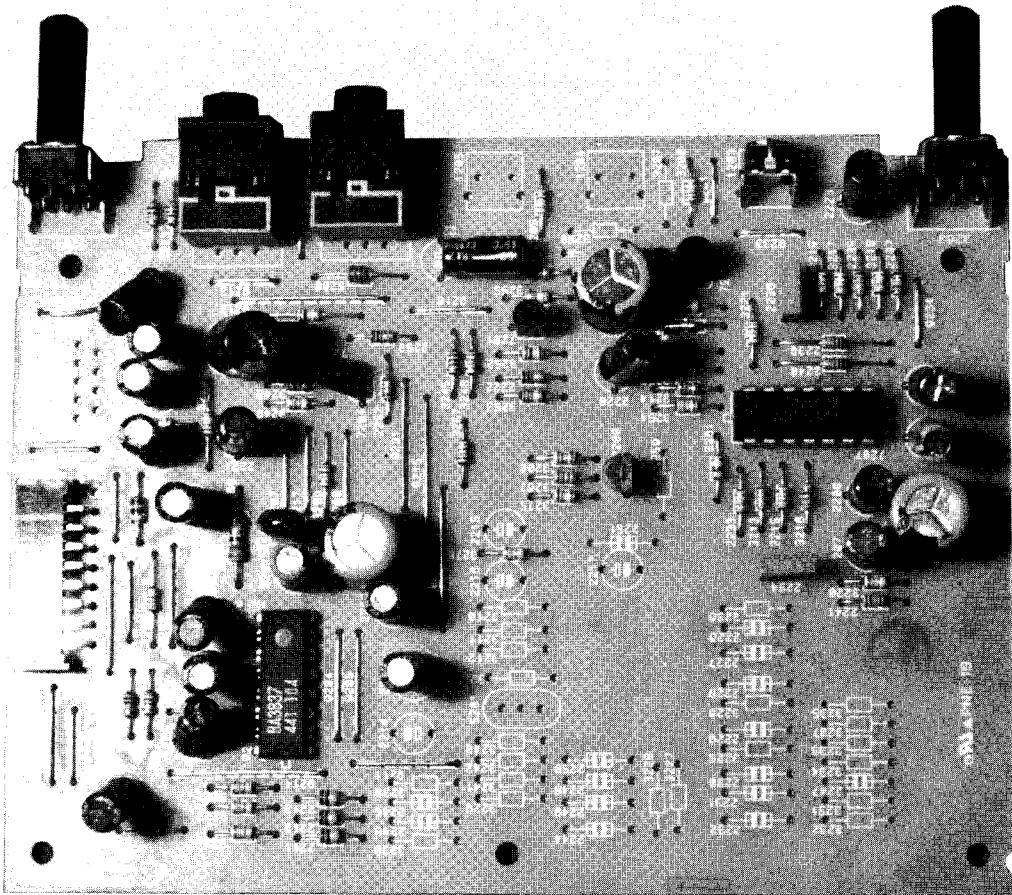
2103	4822 124 40433	47µF	20%	25V
2104	4822 121 42408	220nF	5%	63V
2114	5322 124 41431	22µF	20%	25V
2115	4822 124 40239	0,47µF	20%	63V
2116	5322 121 42386	100nF	5%	63V
2119	4822 124 40244	2,2µF	20%	63V
2120	4822 124 40244	2,2µF	20%	63V
2121	4822 124 40196	220µF	20%	16V
2123	4822 124 40246	4,7µF	20%	63V
2124	4822 124 40246	4,7µF	20%	63V
2129	4822 124 40242	1µF	20%	63V
2131	4822 124 40248	10µF	20%	63V
2140	4822 125 60102	30pF	VARIABLE	
2141	4822 125 60101	10pF	VARIABLE	
2142	4822 125 60102	30pF	VARIABLE	
2144	4822 121 42408	220nF	5%	63V
2145	4822 121 51263	510pF	1%	400V
2146	4822 121 70082	430pF	1%	400V
2152	4822 124 40242	1µF	20%	63V
2156	4822 124 40433	47µF	20%	25V
2160	4822 124 41631	1,5µF	20%	50V
2162	4822 126 11585	22nF+80/-20%		50V
2210	4822 124 41643	100µF	20%	16V

CHIP CAPACITORS

2101	5322 122 34099	470pF	10%	63V
2102	5322 122 32268	470pF	10%	50V
2105	5322 122 32654	22nF	10%	63V
2108	5322 122 32654	22nF	10%	63V
2109	5322 122 32654	22nF	10%	63V
2110	5322 122 32654	22nF	10%	63V
2111	4822 122 32927	220nF	10%	63V
2112	5322 122 32654	22nF	10%	63V
2113	5322 122 32661	56pF	5%	50V
2117	4822 122 33336	8,2nF	10%	50V
2118	4822 122 33336	8,2nF	10%	50V
2125	4822 122 33177	10nF	20%	50V
2126	4822 122 31782	15nF	10%	50V
2127	5322 122 31863	330pF	5%	50V
2128	5322 116 80853	560pF	5%	63V
2132	5322 122 32268	470pF	10%	50V
2133	5322 126 10794	220pF	10%	
2135	4822 122 33128	15nF	10%	63V
2143	5322 122 32531	100pF	5%	50V
2147	5322 122 32654	22nF	10%	63V
2148	5322 122 32452	47pF	5%	50V
2149	4822 122 33177	10nF	20%	50V
2150	5322 122 32654	22nF	10%	63V
2151	5322 122 34099	470pF	10%	63V
2151	4822 122 33219	1,8nF	10%	50V
2153	5322 122 34099	470pF	10%	63V
2154	5322 122 32481	15pF	5%	50V
2155	5322 122 32965	18pF	5%	50V
2158	5322 126 10223	4,7nF	10%	63V
2159	5322 126 10223	4,7nF	10%	63V

CHIP CAPACITORS

2161	4822 122 32927	220nF	10%	63V
2188	5322 122 32654	22nF	10%	63V
2196	5322 122 32448	10pF	5%	50V
2215	5322 122 32268	470pF	10%	50V
2216	5322 122 32268	470pF	10%	50V
2221	5322 122 32268	470pF	10%	50V

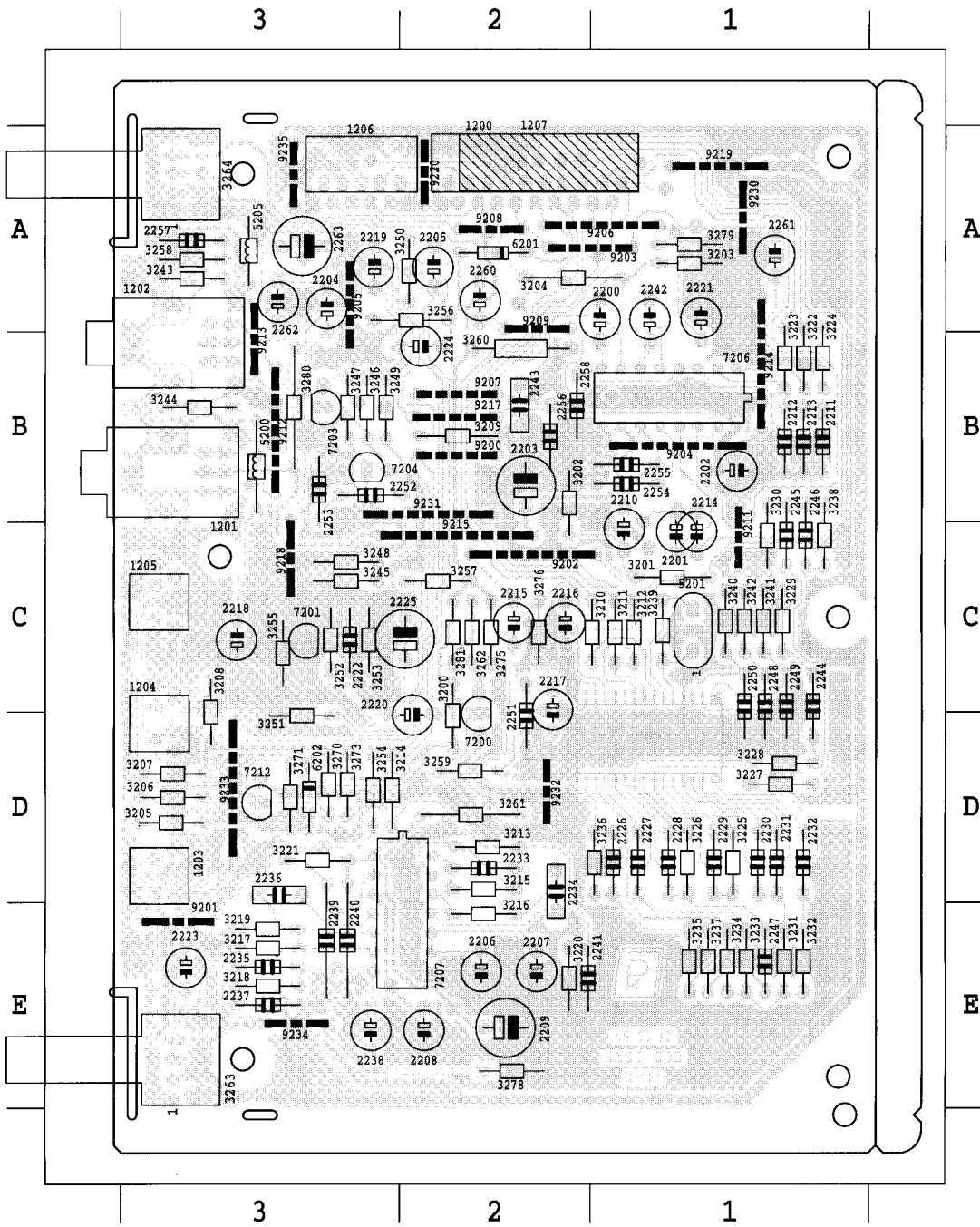


KARAOKE BOARD

TABLE OF CONTENTS

Component layout	8-2
Circuit diagram	8-3
Partslist	8-4

COMPONENT LAYOUT COPPERSIDE VIEW



3254	D 3	2258	B 2	1204	D 3
3255	C 3	2260	A 2	1205	C 3
3256	A 2	2261	A 1	1206	A 3
3257	C 2	2262	A 3	1207	A 2
3258	A 3	2263	A 3	2200	A 1
3259	D 2	3200	D 2	2201	C 1
3260	B 2	3201	C 1	2202	B 1
3261	D 2	3202	B 2	2203	B 2
3262	C 2	3203	A 1	2204	A 3
3263	E 3	3204	A 2	2205	A 2
3264	A 3	3205	D 3	2206	E 2
3270	D 3	3206	D 3	2207	E 2
3271	D 3	3207	D 3	2208	E 2
3273	D 3	3208	D 3	2209	E 2
3275	C 2	3209	B 2	2210	C 1
3276	C 2	3210	C 1	2211	B 1
3278	E 2	3211	C 1	2212	B 1
3279	A 1	3212	C 1	2213	B 1
3280	B 3	3213	D 2	2214	C 1
3281	C 2	3214	D 3	2215	C 2
5200	B 3	3215	D 2	2216	C 2
5201	C 1	3216	E 2	2217	C 2
5205	A 3	3217	E 3	2218	C 3
6201	A 2	3218	E 3	2219	A 3
6202	D 3	3219	E 3	2220	D 2
7200	D 2	3220	E 2	2221	A 1
7201	C 3	3221	D 3	2222	C 3
7203	B 3	3222	B 1	2223	E 3
7204	B 3	3223	B 1	2224	B 2
7205	B 3	3224	B 1	2225	C 2
7206	B 1	3225	D 1	2226	D 1
7207	E 2	3226	D 1	2227	D 1
7212	D 3	3227	D 1	2228	D 1
9200	B 2	3228	D 1	2229	D 1
9201	E 3	3229	C 1	2230	D 1
9202	C 2	3230	C 1	2231	D 1
9203	A 1	3231	E 1	2232	D 1
9204	B 1	3232	E 1	2233	D 2
9205	A 3	3233	E 1	2234	D 2
9206	A 1	3234	E 1	2235	E 3
9207	B 2	3235	E 1	2236	D 3
9208	A 2	3236	D 1	2237	E 3
9209	A 2	3237	E 1	2238	E 3
9211	C 1	3238	C 1	2239	E 3
9212	B 3	3239	C 1	2240	E 3
9213	B 3	3240	C 1	2241	E 2
9214	B 1	3241	C 1	2242	A 1
9215	C 2	3242	C 1	2243	B 2
9217	B 2	3243	A 3	2244	C 1
9218	C 3	3244	B 3	2245	C 1
9219	A 1	3245	C 3	2246	C 1
9220	A 2	3246	B 3	2247	E 1
9230	A 1	3247	B 3	2248	C 1
9231	B 2	3248	C 3	2249	C 1
9232	D 2	3249	B 3	2250	C 1
9233	D 3	3250	A 2	2251	D 2
9234	E 3	3251	D 3	2252	B 3
9235	A 3	3252	C 3	2253	B 3
T313	A 1	3253	C 3	2254	B 1
2255	B 1	1201	B 3		
2256	B 2	1202	B 3		
2257	A 3	1203	D 3		